

# MINI-CYLINDER SERIES "ISO 6432" Ø 8-25 mm AND ACCESSORIES

Mini-cylinders to ISO 6432 with a chamfered stainless steel barrel.

The cylinder head dimensions have been reduced for some sizes so that they can be used where there are space restrictions.

Can be used with different types of sensors.

Available in various versions with a wide range of accessories:

- with or without magnet
- single and double acting – single or through rod
- with pneumatic cushioning (Ø16-20-25)
- gaskets made of NBR, POLYURETHANE, and FKM/FPM (for high temperatures), and low-temperature gaskets
- special executions on request
- fixing accessories, guide units and mechanical rod locking



TECHNICAL DATA	Polyurethane	NBR	FKM/FPM	Low temperature
Operating pressure	max 10 bar (max 1 MPa)			
Temperature range	-10°C ÷ +80°C	-10°C ÷ +80°C	-10°C ÷ +150°C (non-magnetic cylinders)	-35°C to +80°C
Fluid	Unlubricated air. Lubrication, if used, must be continuous			
Bores	Ø8; Ø10; Ø12; Ø16; Ø20, Ø25;			
Design	Chamfered barrel			
Standard strokes	Single-acting:	for bores Ø8-25 strokes from 0 to 50 mm		
	Double-acting:	for bores Ø8-10 strokes from 0 to 100 mm		
		for bores Ø12-16 strokes from 0 to 200 mm		
		for bores Ø20-25 strokes from 0 to 500 mm		
	Double-acting, cushioned:	for bores Ø16 strokes from 0 to 300 mm		
		for bores Ø20-25 strokes from 0 to 500		
Versions	Double-acting, Double-acting cushioned, Single-acting retracted piston rod, Through-rod, Through-rod cushioned, Version with piston rod block.			
Magnet for sensors	All versions come complete with magnet. Supplied without magnet on request.			
Inrush pressure	Ø8 to Ø12: 0.8 bar - Ø16 to Ø25: 0.6 bar			
Forces generated at 6 bar thrust/retraction	See GENERAL CATALOGUE PAGE 1.1/05			
Weights	See GENERAL CATALOGUE PAGE 1.1/06			
	For non-stick slip versions, are unlubricated air only			

## COMPONENTS

- ① PISTON ROD: C45 steel or stainless steel, thick chromed
- ② HEAD: anodised aluminium alloy
- ③ PISTON ROD GASKET: SFR (PARKER PRADIFA) self-lubricating, NBR or FKM/FPM
- ④ GUIDE BUSHING: steel strip with bronze and PTFE insert
- ⑤ BARREL: AISI 304 steel
- ⑥ HALF-PISTON: acetal resin
- ⑦ PISTON ROD GASKET: polyurethane (PARKER PRADIFA), NBR or FKM/FPM
- ⑧ MAGNET: plasteodymium
- ⑨ CUSHIONING GASKET: NBR or FKM/FPM
- ⑩ NEEDLE: OT 58 with needle out movement safety system even when fully open
- ⑪ BUSHING (optional): self-lubricating bronze

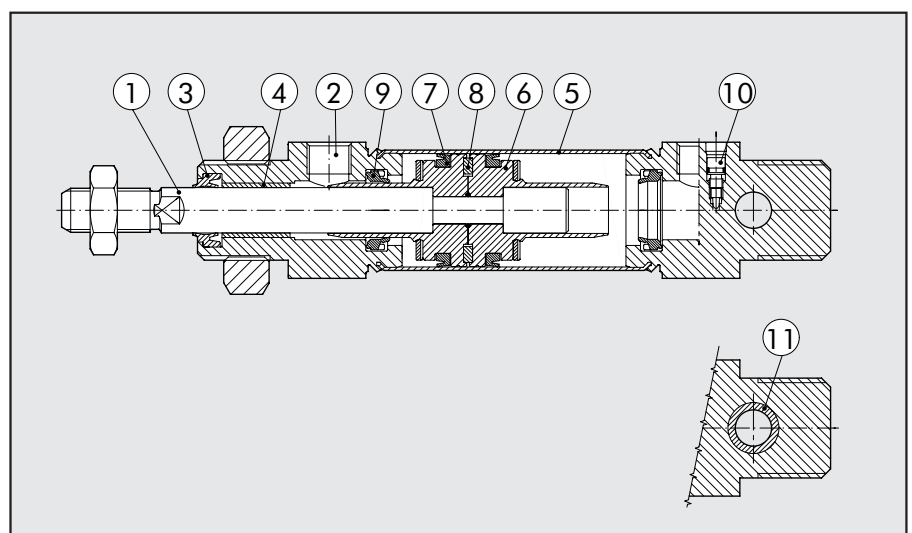



## DIMENSIONS OF STANDARD VERSIONS

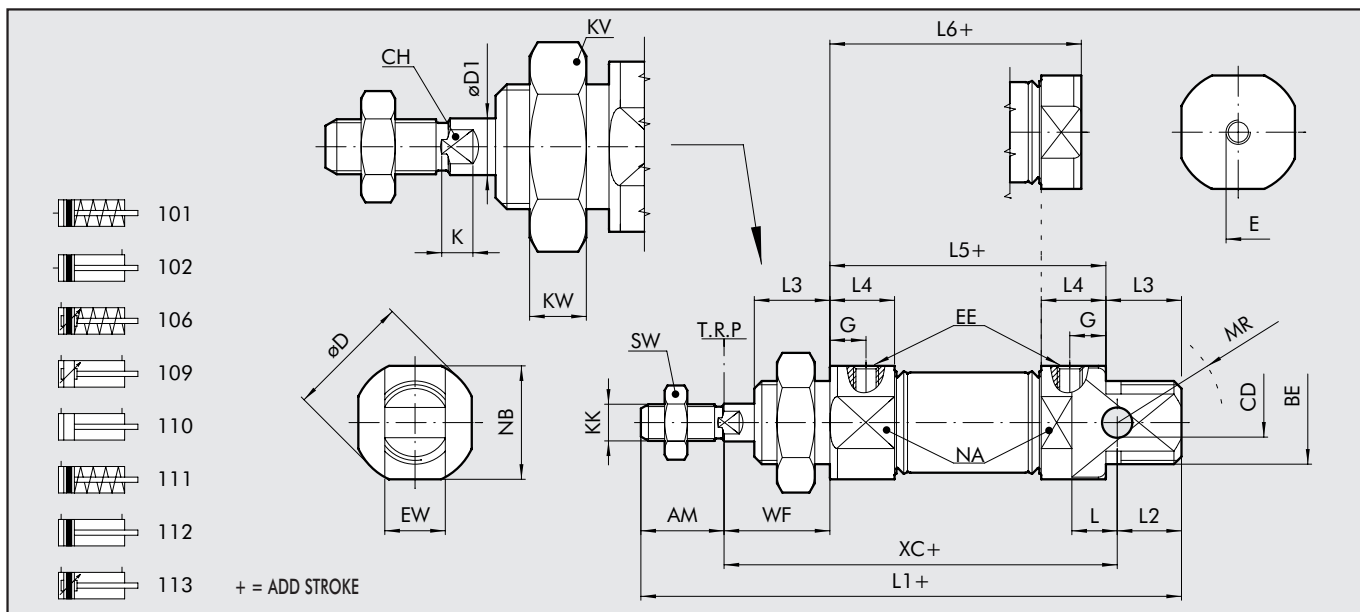

Ø	AM (+0.0;-2.0)	BE	øCD (H9)	øD	øD1	E	G	EE	EW (d13)	L	L1	L2	L3	L4	L5	L6	KK	XC±1	WF (±1,2)	KW	KV	MR	NA	NB	SW	CH	K
8	12	M12x1,25	4	16.7	4	M5	6	M5	8	6.5	86	10	12	10	46	46	M4	64	16	7	19	12	15	15	7	3	3
10	12	M12x1,25	4	16.7	4	M5	6	M5	8	6.5	86	10	12	10	46	46	M4	64	16	7	19	12	15	15	7	3	3
12	16	M16x1,5	6	19	6	M5	6	M5	12	9	104	13	17	10	49	47	M6	75	22	8	24	16	17	17	10	5	3,5
16	16	M16x1,5	6	19.7	6	1/8	6	M5	12	9	111	13	17	10	56	53	M6	82	22	8	24	16	20	18	10	5	3,5
20	20	M22x1,5	8	27.9	8	1/8	8	G 1/8	16	12	129	14	17	15.5	68	61	M8	95	24	10	32	18	28	24	13	7	4,6
25	22	M22x1,5	8	33	10	1/8	9	G 1/8	16	12	143	17	20	17.1	73	66.5	M10x1,25	104	28	10	32	21	30	30	17	8	5

## DIMENSIONS OF STANDARD VERSIONS WITH THROUGH-ROD

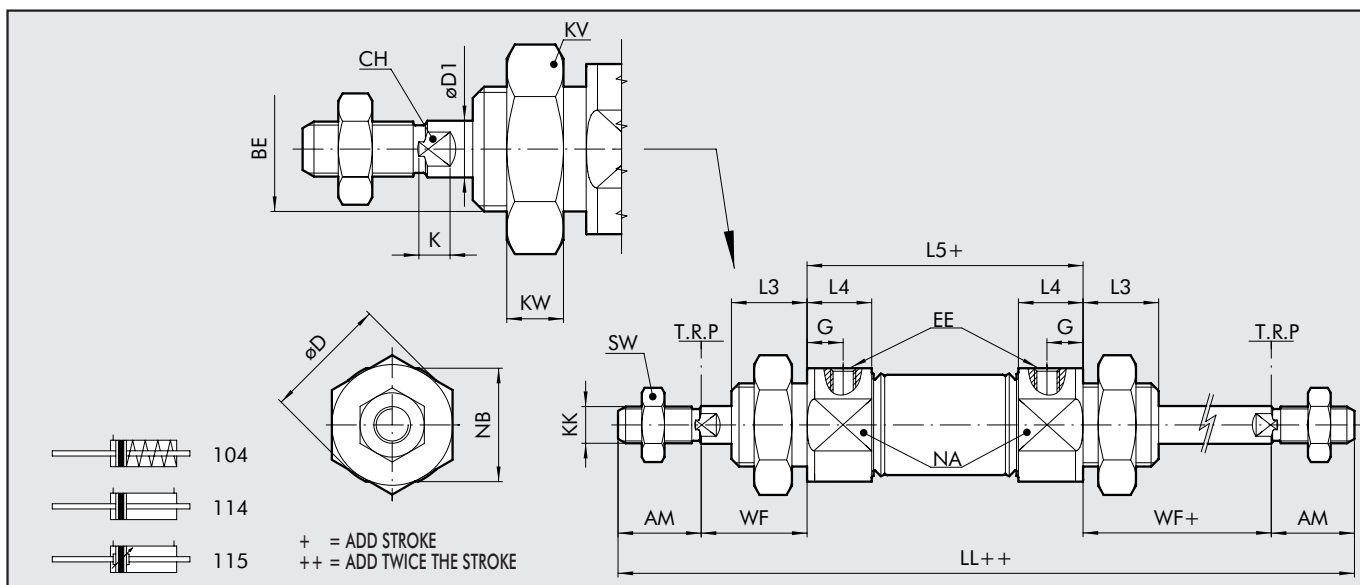

Ø	AM (+0.0;-2.0)	BE	øD	øD1	G	EE	LL	L3	L4	L5	KK	WF (±1,2)	KW	KV	NA	NB	SW	CH	K
8	12	M12x1,25	16.7	4	6	M5	102	12	10	46	M4	16	7	19	15	15	7	3	3
10	12	M12x1,25	16.7	4	6	M5	102	12	10	46	M4	16	7	19	15	15	7	3	3
12	16	M16x1,5	19	6	6	M5	125	17	10	49	M6	22	8	24	17	17	10	5	3,5
16	16	M16x1,5	19.7	6	6	M5	132	17	10	56	M6	22	8	24	20	18	10	5	3,5
20	20	M22x1,5	27.9	8	8	G 1/8	156	17	15.5	68	M8	24	10	32	28	24	13	7	4,6
25	22	M22x1,5	33	10	9	G 1/8	173	20	17.1	73	M10x1,25	28	10	32	30	30	17	8	5

### KEY TO CODES

CYL	1	1	2	0	1	6	0	0	2	0	C	P	
	TYPE			DIAMETER			STROKE						
	101	SE axial coupling		0	Standard	▼ 08	+	Ø 8÷10			A	C45 chrome rod, aluminium piston rod	P polyurethane
	102	DEM axial coupling		U	Bronze rear head bushing	▼ 10	+	stroke 0÷100 mm			C	C45 chrome rod, technopolymer piston rod	N NBR
	104	SE through-rod		V	Without head nut	16	+	stroke 0÷200 mm					● V FKM/FPM
■	106	SE cushioned		S	Non-magnetic	20	+	stroke 0÷25			Z	Stainless steel piston rod and nut	● B low temperature
■	109	DEA		▲ G	No stick slip	25		stroke 0÷500 mm			X	Stainless steel piston rod and nut	
	110	DE											
	111	SE											
	112	DEM											
■	113	DEMA											
*▼	114	DEM through-rod											
*▼■	115	DEMA through-rod											
◆	116	DEM for mechanical lock											
■	117	DEMA for mechanical lock											

DE: Double-acting (non-cushioned, not magnetic)  
 DEM: Magnetic double-acting (non-cushioned)  
 DEMA: Magnetic double-acting (cushioned)  
 DEA: Cushioned double-acting (non-magnetic)  
 SE: Single-acting (magnetic)

- Only available for non-magnetic versions (S) and with aluminium piston (A or Z)
- +
- Maximum recommended strokes. Higher values can create operating problems
- ▲ Not available for NBR (N) versions
- ▼ Stainless steel piston rod
- Available from Ø16
- ◆ Available from Ø12
- \* For ø16÷25 aluminium piston

## ACCESSORIES: FIXINGS

### FOOT MODEL A

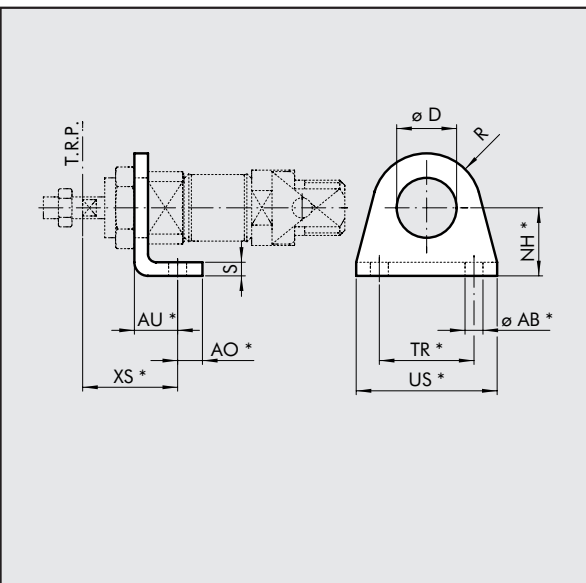

Code	Ø	D	XS (±1.4)	AU	AO	NH (±0.3)	TR (Js14)	US
W0950080001	8	12	24	11	5	16	25	35
W0950080001	10	12	24	11	5	16	25	35
W0950120001	12	16	32	14	6	20	32	42
W0950120001	16	16	32	14	6	20	32	42
W0950200001	20	22	36	17	8	25	40	54
W0950200001	25	22	40	17	8	25	40	54

\*ISO 6432 values

Code	AB (H13)	R	S	Weight [g]
W0950080001	4.5	10	3	22
W0950080001	4.5	10	3	22
W0950120001	5.5	13	4	42
W0950120001	5.5	13	4	42
W0950200001	6.5	20	5	90
W0950200001	6.5	20	5	90

\*ISO 6432 values

Note: Individually packed



**FLANGE MODEL C**

Code	Ø	D	W (±1.4)	FB (H13)	TF (Js14)	UF	UR	S	Weight [g]
------	---	---	----------	----------	-----------	----	----	---	------------

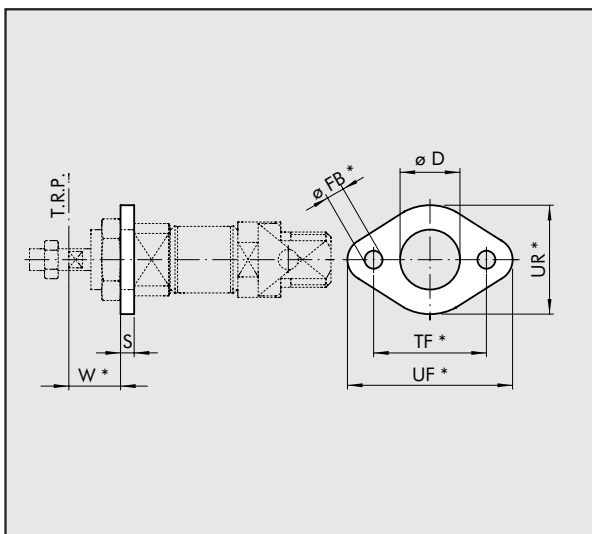

W0950080002	8	12	13	4.5	30	40	22	3	10
W0950080002	10	12	13	4.5	30	40	22	3	10
W0950120002	12	16	18	5.5	40	52	30	4	26
W0950120002	16	16	18	5.5	40	52	30	4	26
W0950200002	20	22	19	6.5	50	66	40	5	52
W0950200002	25	22	23	6.5	50	66	40	5	52

\*ISO 6432 values

Note: Individually packed

**COUNTER-HINGE MODEL BC**

Code	Ø	AO	LG	TR (Js13)	NH (±0.2)	MO	AB1	AB (H13)	R	S	Weight [g]
------	---	----	----	-----------	-----------	----	-----	----------	---	---	------------

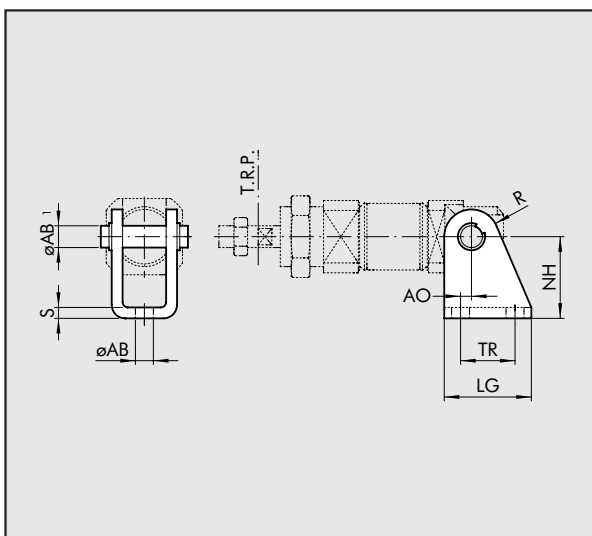

W0950080005	8	2.5	22	12.5	24	18	4	4.5	6	2.5	24
W0950080005	10	2.5	22	12.5	24	18	4	4.5	6	2.5	24
W0950120005	12	2	25	15	27	25	6	5.5	7	3	40
W0950120005	16	2	25	15	27	25	6	5.5	7	3	40
W0950200005	20	4	32	20	30	30	8	6.5	10	4	78
W0950200005	25	4	32	20	30	30	8	6.5	10	4	78

\*ISO 6432 values

Note: Supplied complete with 1 pin and 2 snap rings

**NUT FOR HEADS MODEL D**

Code	Ø	F	CH	H	Weight [g]
------	---	---	----	---	------------

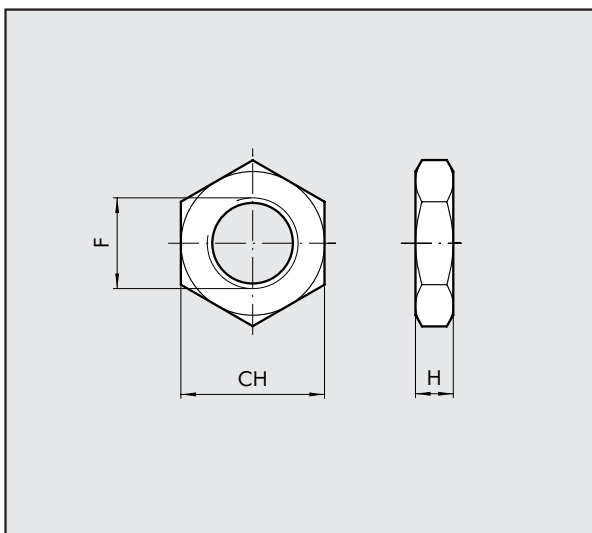

0950080010	8	M12x1.25	19	7	12
0950080010	10	M12x1.25	19	7	12
0950120010	12	M16x1.5	24	8	20
0950120010	16	M16x1.5	24	8	20
0950200010	20	M22x1.5	32	10	44
0950200010	25	M22x1.5	32	10	44

Note: Individually packed

### NUT FOR PISTON RODS MODEL DA

Code      Ø      F      CH      H      Weight [g]

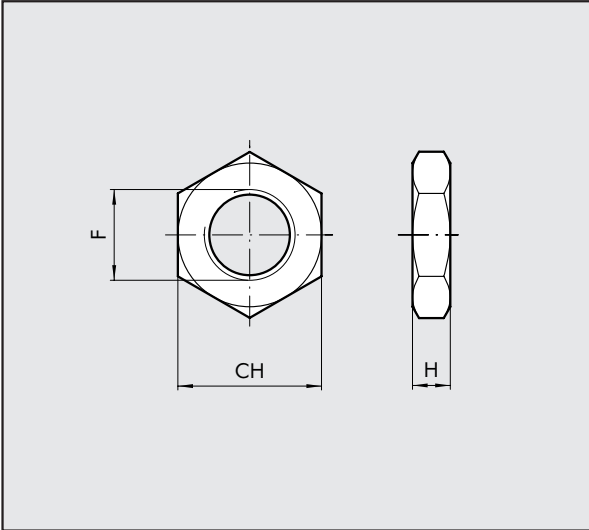

0950080011	8	M4	7	3	0.6
0950080011	10	M4	7	3	0.6
0950120011	12	M6	10	4	1
0950120011	16	M6	10	4	1
0950200011	20	M8	13	5	3
0950322010	25	M10x1.25	17	6	7

Note: Individually packed

### FORK MODEL GK-M

Code      Ø      ØM      C      B      A      L      F      D      N      Weight [g]

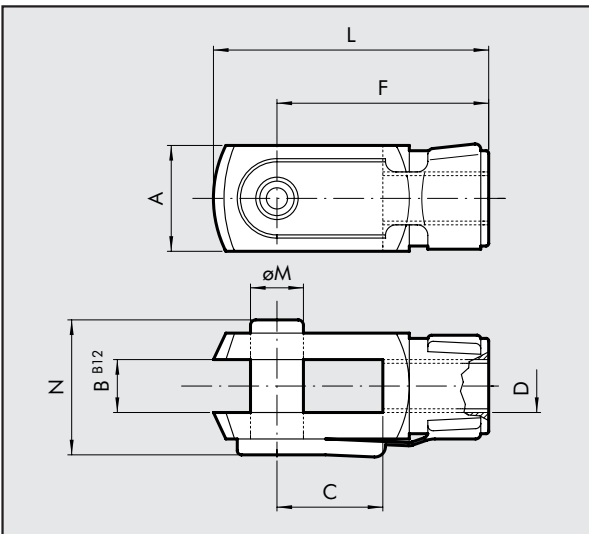

W0950080020	8	4	8	4	8	21	16	M4	11	8
W0950080020	10	4	8	4	8	21	16	M4	11	8
W0950120020	12	6	12	6	12	31	24	M6	16	20
W0950120020	16	6	12	6	12	31	24	M6	16	20
W0950200020	20	8	16	8	16	42	32	M8	22	48
W0950322020	25	10	20	10	20	52	40	M10x1.25	26	92

Note: Individually packed

### ROD EYE MODEL GA-M

Code      Ø      ØM      C      B      B1      A      L      F      D      øG      øG1      CH      Weight [g]

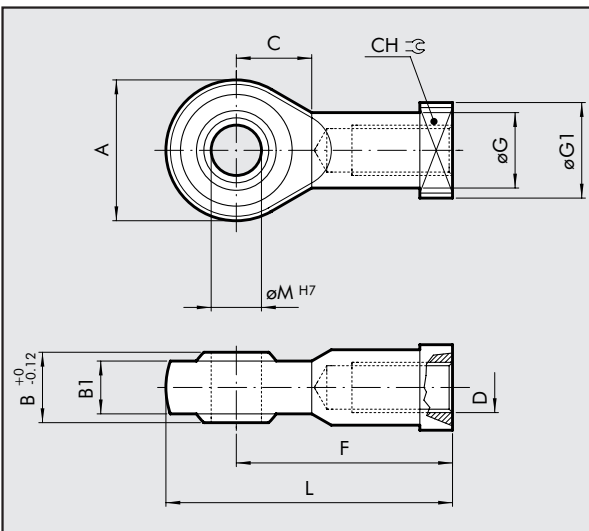

W0950080025	8	5	10	8	6	18	36	27	M4	9	11	9	22
W0950080025	10	5	10	8	6	18	36	27	M4	9	11	9	22
W0950120025	12	6	11	9	6.75	20	40	30	M6	10	13	11	28
W0950120025	16	6	11	9	6.75	20	40	30	M6	10	13	11	28
W0950200025	20	8	13	12	9	24	48	36	M8	12.5	16	14	50
W0950322025	25	10	15	14	10.5	28	57	43	M10x1.25	15	19	17	78

Note: Individually packed

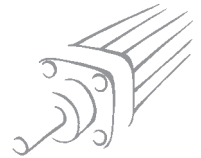

# ACCESSORIES: MAGNETIC SENSORS

1

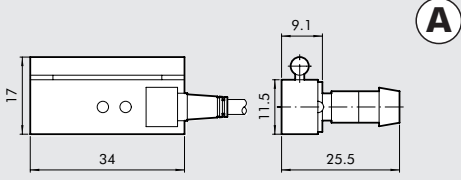
SENSORS MOD. DSM	Code	Bore	Model
	W0950000201	8÷25	REED SENSOR ACC. DSM2 - C525
	W0950000222	8÷25	E. HALL PNP SENSOR ACC. DSM3-N225
	W0950000232	8÷25	E. HALL NPN SENSOR ACC. DSM3-M225

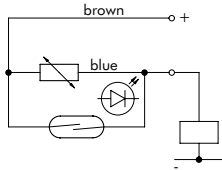
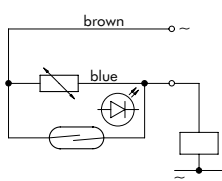
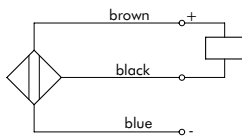
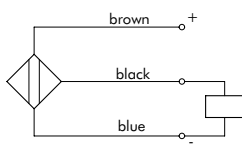
TECHNICAL DATA		REED+VARISTOR+LED 2 wires	HALL VERSION PNP/NPN 3 wires
Type		REED+VARISTOR+LED NO	HALL EFFECT NO PNP/NPN
Contact		3 to 48 (DC): 3 to 220 (AC)	6-24 V DC
Max AC/DC voltage	V		
Max current at 25°C	mA	500	250
Power with inductive load	VA	10	-
Power with resistive load	Watt	50	6
Switch-on time	m sec	1.2	0.8
Switch-off time	m sec	0.1	3
Switch-on point	Gauss	110	15
Switch-off point	Gauss	95	8
Operating life	-	10 <sup>7</sup> impulses	10 <sup>9</sup> impulses
Contact resistance		0.1	-
Cable length	m	2.5	2.5
Cable cross section	mm <sup>2</sup>	0.35	0.35
Cable material		Soft PVC	Soft PVC
Circuit		<p><b>DC</b></p>  <p><b>AC</b></p> 	<p><b>Version NPN</b></p>  <p><b>Version PNP</b></p> 

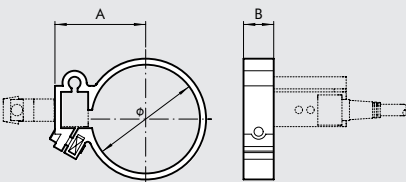
SENSOR CIRCLIP MOD. DXF	Code	Bore	Model	Ø	A	B
	<b>FOR ALUMINIUM BARREL</b>					
	W0950000108	8	FASCETTA DXF 12- 8	12	17	10
	W0950000110	10	FASCETTA DXF 14-10	14	18	10
	W0950000112	12	FASCETTA DXF 16-12	16	19	10
	W0950000116	16	FASCETTA DXF 20-16	20	21	10
	W0950000120	20	FASCETTA DXF 24-20	24	23	10
	W0950000125	25	FASCETTA DXF 29-25	29	28	10
	<b>Note: Individually packed</b>					
	<b>FOR STAINLESS STEEL BARREL</b>					
	W0950000508	8	FASCETTA DXF - 09	9.3	15	10
W0950000510	10	FASCETTA DXF - 11	11.3	16.5	10	
W0950000512	12	FASCETTA DXF - 13	13.3	17.5	10	
W0950000516	16	FASCETTA DXF - 17	17.3	18.5	10	
W0950000520	20	FASCETTA DXF - 21	21.3	21	10	
W0950000525	25	FASCETTA DXF - 26	26.3	23.5	10	
<b>Note: Individually packed</b>						

6

### RETRACTING SENSOR

Code Description

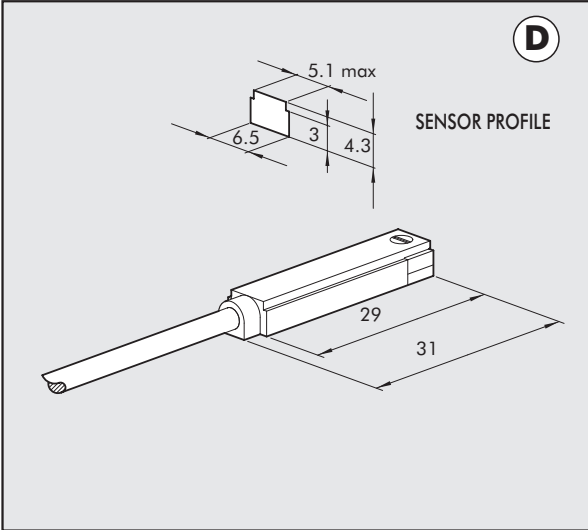

- W0950025390 Hall sensor DSL, 3 wires, NO 2.5 m
- W0950029394 Hall sensor DSL, 3 wires, NO 300 mm M8
- W0950022180 REED sensor DSL, 2 wires, NO 2.5 m
- W0950028184 REED sensor DSL, 2 wires, NO 300 mm M8

Note: Individually packed

### WIRING DIAGRAM

### TECHNICAL DATA

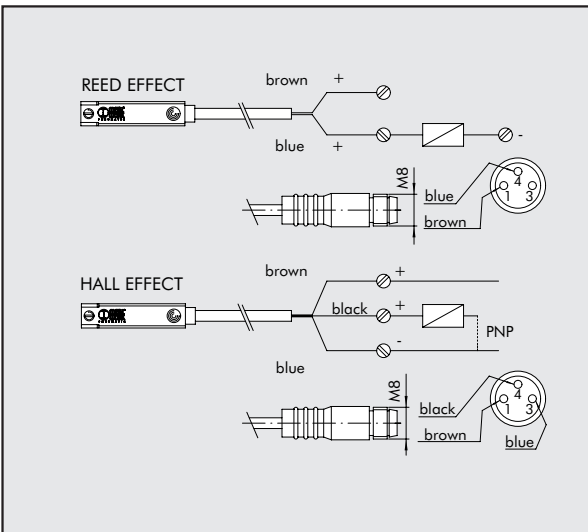

	Reed	Hall effect
Type of contact	N.O.	N.O.
Switch	-	PNP
DC voltage range	V 3÷30	6÷30
AC voltage range	V 3÷30	-
Absorption	A 0.1	0.2
DC power	W 6	4
AC power	VA 6	-
Temperature range	°C -20÷ +85	
Activation time	s 0.5µs	0.8µs
Risk time	s 0.1µs	0.3µs
Life	imp 10 million	10 <sup>3</sup> million
Contact resistance	Ω 0.1	-
Degree of protection	IP 65	
Voltage drop	V 3	1
Number of wires	2	3

### RETRACTABLE SENSOR WITH INSERTION FROM ABOVE

Code Description

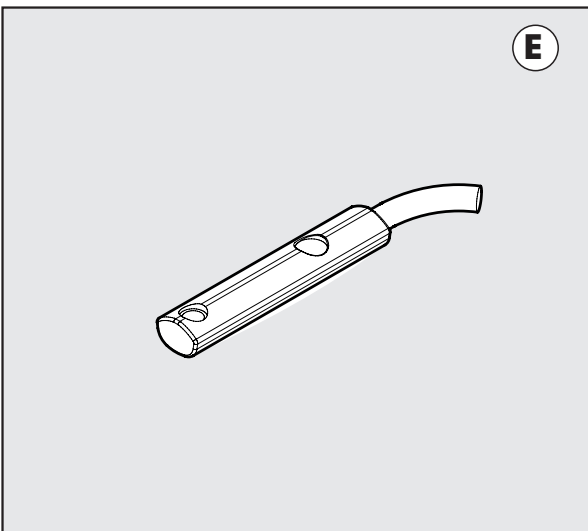

- W0952025390 HALL N.O. SENSOR, VERTICAL INSERTION 2.5m
- W0952029394 HALL N.O. SENSOR, VERTICAL INSERTION 300 mm M8
- W0952022180 REED N.O. SENSOR, VERTICAL INSERTION 2.5m
- W0952028184 REED N.O. SENSOR, VERTICAL INSERTION 300 mm M8

Note: Individually packed



WIRING DIAGRAM

TECHNICAL DATA

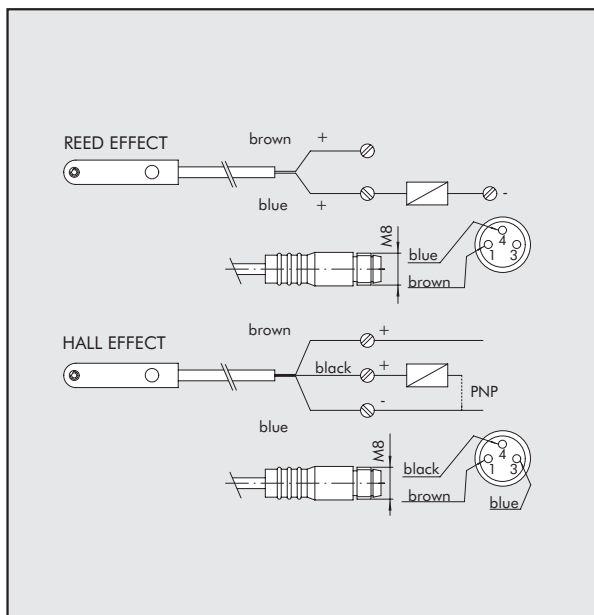

	Reed	Effetto Hall
Type of contact	N.O.	N.O.
Switch	-	PNP
Supply voltage (U <sub>b</sub> )	V 10 ÷ 30 AC/DC	10 ÷ 30 DC
Power	W 3 (peak valve=6)	3
Voltage variation	-	≤ 10% of U <sub>b</sub>
Voltage drop	V -	≤ 2
Input current	mA -	≤ 10
Output current	mA ≤ 100	≤ 100
Switching frequency	Hz ≤ 400	≤ 5
Short-circuit protection	-	Yes
Over-voltage suppression	-	Yes
Polarity inversion protection	-	Yes
EMC	EN 60 947-5-2	EN 60 947-5-2
LED display	Yellow	Yellow
Magnetic sensitivity	2,8 mT ±25%	2,8 mT ±25%
Repeatability	≤ 0,1 mT	≤ 0,1 mT
Degree of protection (EN 60529)	IP 67	IP 67
Vibration and shock resistance	30 g, 11 ms, 10÷55 Hz, 1mm	30 g, 11 ms, 10÷55 Hz, 1mm
Temperature range	°C -25 ÷ +75	-25 ÷ +75
Sensor capsule material	PA66 + PA6I/6T	PA66 + PA6I/6T
2.5m connecting cable	PVC; 2 x 0,12 mm <sup>2</sup>	PVC; 3 x 0,14 mm <sup>2</sup>
Connecting cable with M8x1	Polyurethane; 2 x 0,14 mm <sup>2</sup>	Polyurethane; 3 x 0,14 mm <sup>2</sup>

SENSOR CIRCLIP MOD. DSW

Code	Bore	Model	Ø	ØB	C	D	E	F
------	------	-------	---	----	---	---	---	---

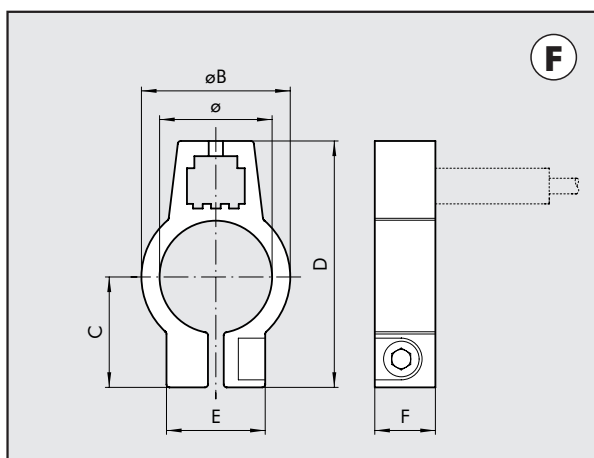

W0950000608	8	CIRCLIP DSW - 08	9.3	12.3	11	24	12.3	9
W0950000610	10	CIRCLIP DSW - 10	11.3	14.3	12	26	12.3	9
W0950000612	12	CIRCLIP DSW - 12	13.3	16.3	13	28	12.3	9
W0950000616	16	CIRCLIP DSW - 16	17.3	20.3	15.5	32	12.3	9
W0950000620	20	CIRCLIP DSW - 20	21.3	24.3	17.5	36	14	9
W0950000625	25	CIRCLIP DSW - 25	26.3	29.3	20	41.5	14	9

Note: Individually packed

UNIVERSAL SENSOR CIRCLIP

Code	Bore	Model
------	------	-------

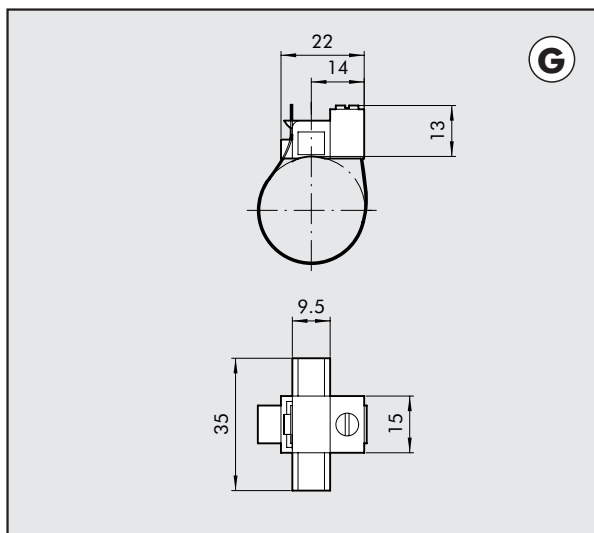

W0950001103	8÷25	SENSOR CIRCLIP
-------------	------	----------------

Note: Individually packed

MATERIAL

Circlip: stainless steel  
Sensor holder: plastic

USE SENSORS

**OLD**  
(aluminium barrel)

**NEW**  
(steel barrel)

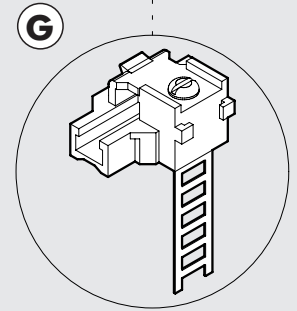
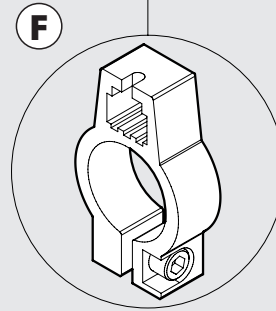
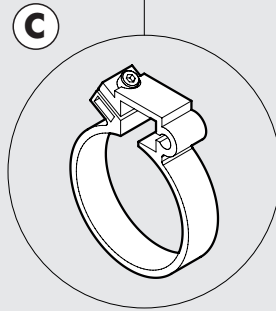
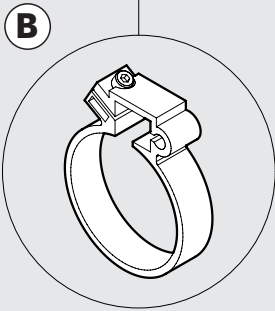
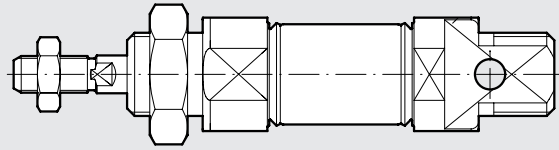
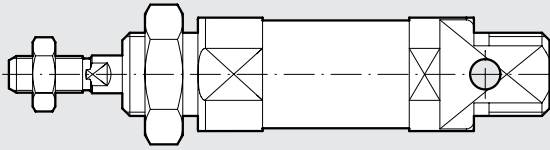

**B**  
DXF  
W09500001 \_\_

**C**  
DXF  
W09500005 \_\_

**F**  
DSW  
W09500006 \_\_

**G**  
W0950001103

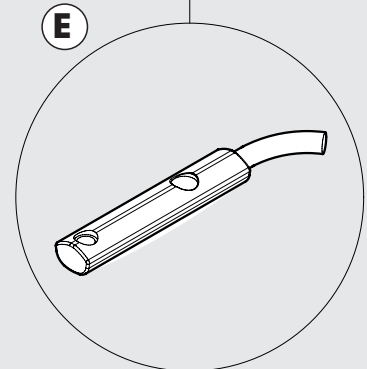
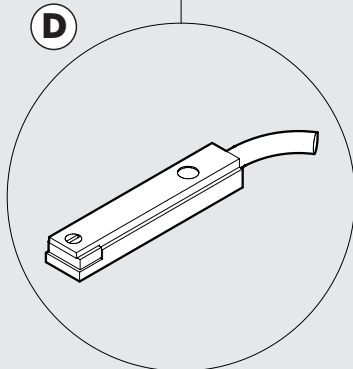
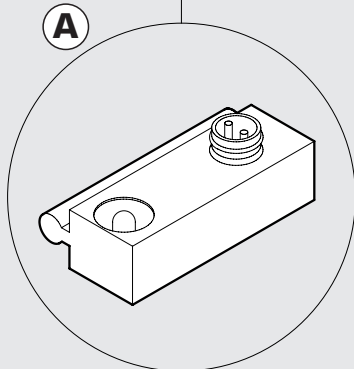

**A**  
W0950000201

...  
...  
...

**D**  
W0950022180

...  
...  
...

**E**  
W0952022180

...  
...  
...

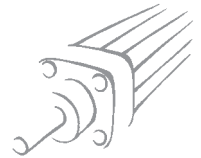

# ACCESSORIES FOR MECHANICAL PISTON ROD LOCK

1

## TECHNICAL DATA

Operating pressure	3-6 bar (0.3-0.6 Mpa)
Temperature range	Max 80°C
Fluid temperature	Max 70°C
Installation	in any position
Mechanics	double shoe with mechanical locking
Operation	NC bidirectional
Fluid	lubricated or unlubricated compressed air
Locking force	Ø 12-16: 180 N / Ø 20: 250 N / Ø 25: 400 N
Pilot port	M5
Body material	Aluminium
Shoe material	Brass
Spring material	NBR
Piston material	Synthetic, with added teflon
Gasket material	NBR

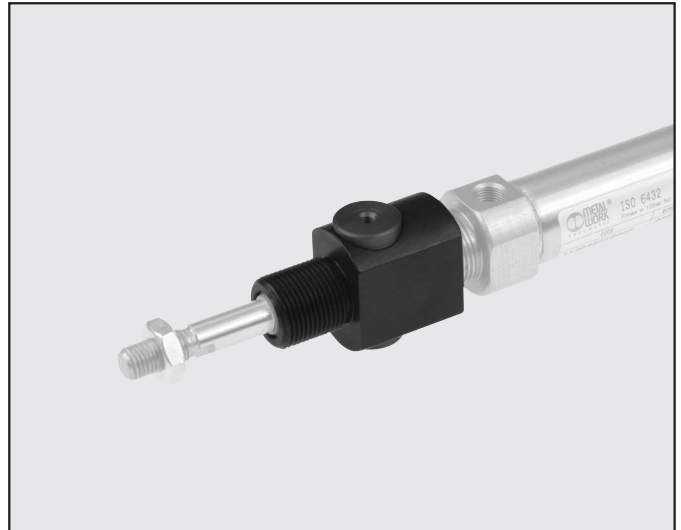

## OPERATING PRINCIPLE

The mechanical piston rod lock is a normally-closed mechanism. In the absence of pneumatic piloting, the two shoes (A) lock the cylinder rod in both directions (Fig. 1). With pneumatic piloting, the piston rod guide forces the shoes to come right up to each other and overcome the counter spring (B) force and the piston rod can slide (Fig. 2). It is important to remember that the mechanical piston rod lock is a static type, which means that it is necessary to stop the cylinder piston rod pneumatically before locking the part mechanically.

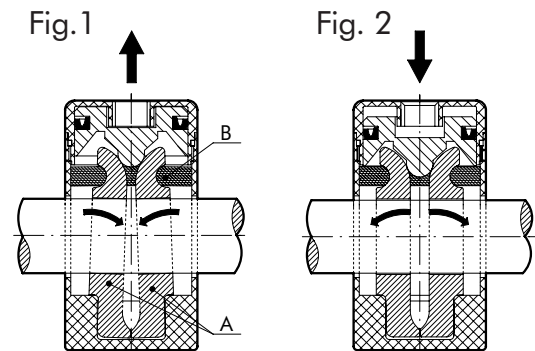

## DIMENSIONS

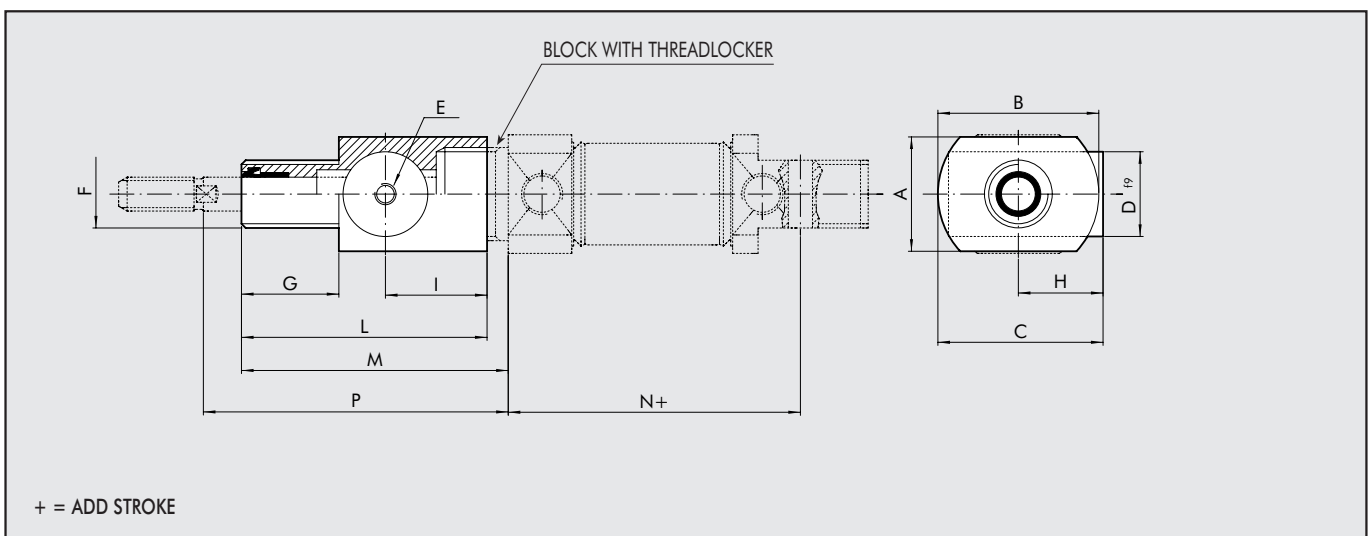

+ = ADD STROKE

Code	Ø	A	B	C	D	E	F	G	H	I	L	M	N	P(±1.2)	Weight [g]
W5010001098	12	25	25	31.5	20	M5	M16x1.5	12	19	23	47	50	53	55	100
W5010001098	16	25	25	31.5	20	M5	M16x1.5	12	19	23	47	50	60	55	100
W5010001100	20	27	38	40	20	M5	M22x1.5	23	21	24	58	65	71	72	100
W5010001101	25	27	38	40	20	M5	M22x1,5	23	21	24	58	68	76	76	100

Guide units series DS-DH-DM ensure optimal alignment and anti-rotation effect of the pneumatic cylinder connected to it. The guide units can be used separately or combined in order to get complete handling units: in which case the guide units can be coupled using the type A and C anchorage (foot and flange).

The guide unit can be coupled to ISO 6432 cylinders (Ø 12 - Ø 25). The following versions are available:

U PROFILE\*: for limited loads and speeds (GDS)

H PROFILE\*: for high loads (GDH)

H PROFILE\*\*: for high speeds (GDM)

(For weights, see GENERAL CATALOGUE page 1.1/07)

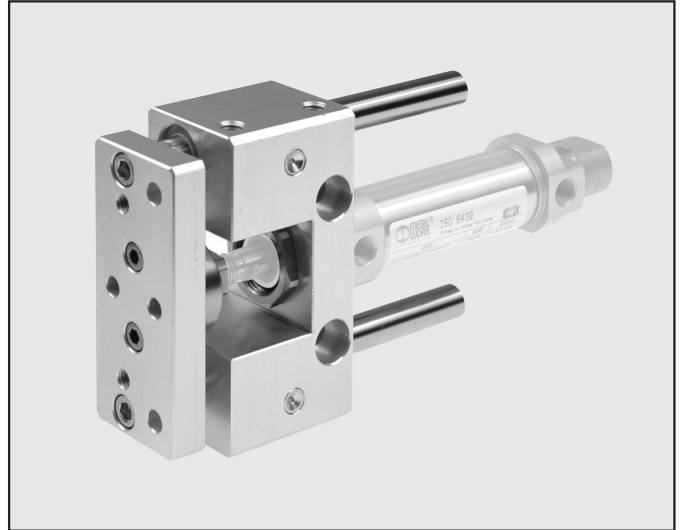

\*With bronze guide bushing

\*\*With ball guide bushing

## GUIDE ELEMENTS

SERIES GDS-GDH	Body:	aluminium alloy
	Guide bushing:	self-lubricating sintered bronze and wiper rings
	Piston rod:	chromed rolled steel
SERIES GDM	Body:	aluminium alloy
	Guide bushing:	linear guide ball bearings and wiper rings
	Piston rod:	tempered and chromed steel

## GUIDE UNIT LOAD DIAGRAM

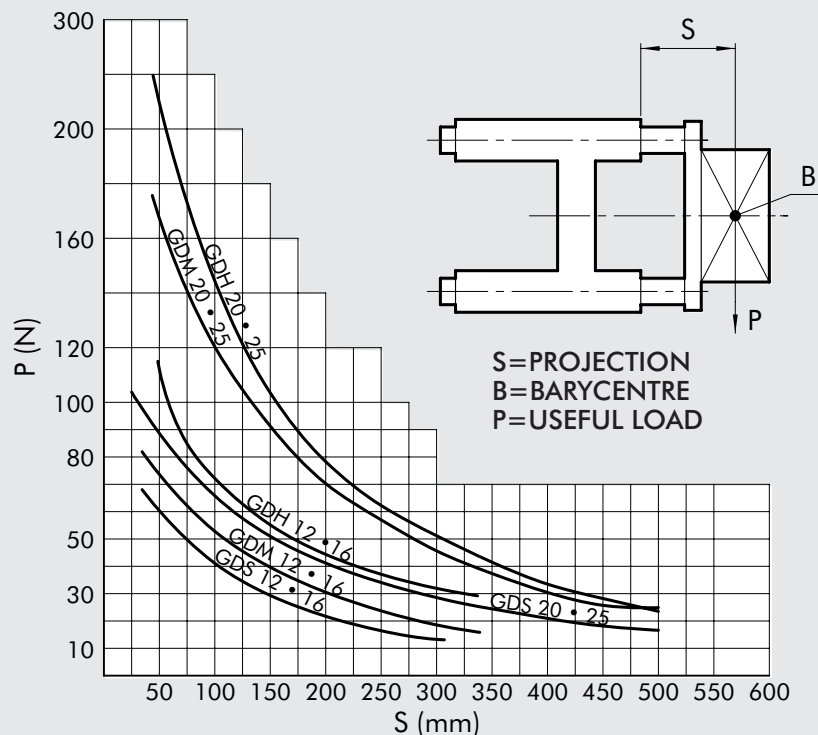



## DIMENSIONS OF TYPE GDH-GDM

1

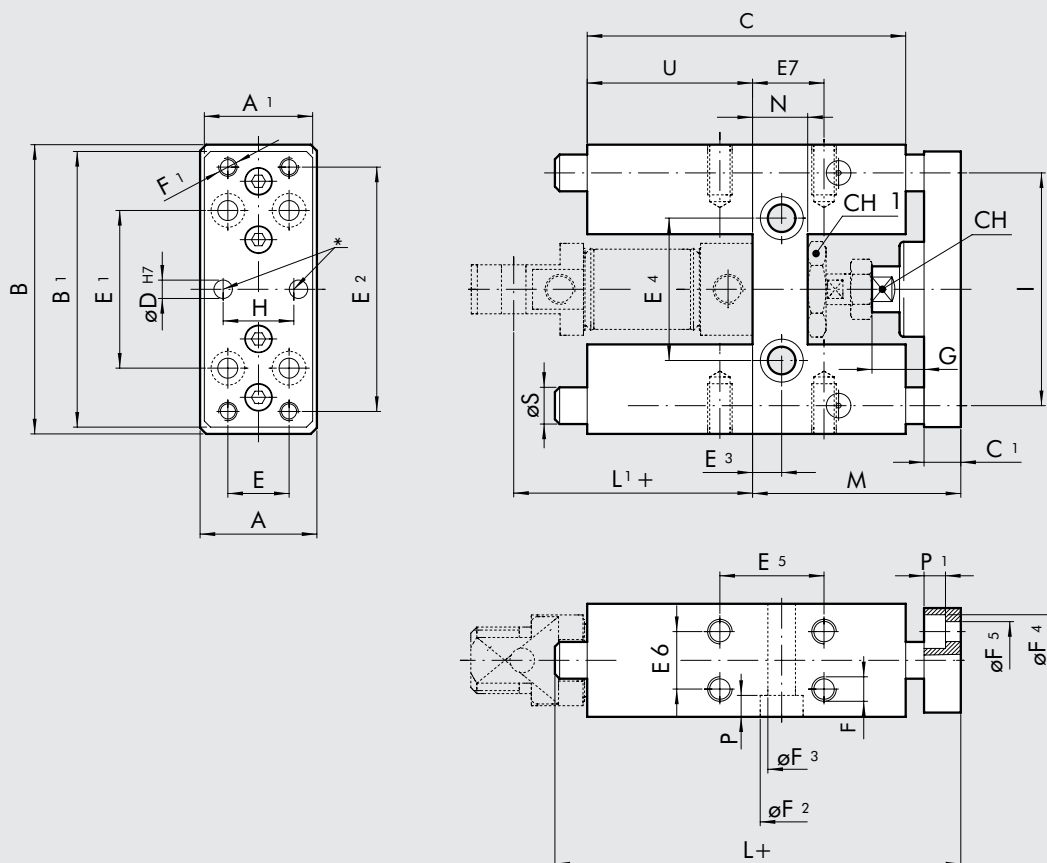

+ = ADD THE STROKE  
\* = CENTERING PINHOLES

Ø	A	A <sub>1</sub>	B	B <sub>1</sub>	C	C <sub>1</sub>	Ch	Ch <sub>1</sub>	D	E	E <sub>1</sub>	E <sub>2</sub>	E <sub>3</sub>	E <sub>4</sub>	E <sub>5</sub>	E <sub>6</sub>	E <sub>7</sub>	F	F <sub>1</sub>	F <sub>2</sub>	F <sub>3</sub>	F <sub>4</sub>	F <sub>5</sub>	G	H	I	L	L <sub>1</sub>	M	N	P	S	U
12	30	27	65	63	75	10	8	19	4	15	32	54	6,5	24	32,5	22	11	M4	M4	8,5	5,1	7,5	4,5	12	15	46	130	53	51	15	5,5	8	37
16	30	27	65	63	75	10	8	19	4	15	32	54	6,5	24	32,5	22	11	M4	M4	8,5	5,1	7,5	4,5	12	15	46	130	60	51	15	5,5	8	37
20	34	32	79	76	108	12	12	27	6	20	40	68	8,5	38	32,5	23	15	M6	M5	10,5	6,5	9	5,5	22	20	58	159	71	65	15	6,5	10	58
25	34	32	79	76	108	12	12	27	6	20	40	68	8,5	38	32,5	23	15	M6	M5	10,5	6,5	9	5,5	17	20	58	159	76	65	15	6,5	10	58

Note:	Cylinder stroke		Guide stroke
	from mm.	to mm.	
Thanks to the dimensional features, it is possible to extend the use of GDH/GDM guides to cylinders with strokes up to 25 mm above the nominal guide stroke. The table here shows the stroke/cylinder range that can be used depending on the nominal stroke of the guide.	0	75	50
	75	125	100
	125	175	150
	175	225	200
	225	275	250
	275	345	320
	345	425	400
	425	525	500

Ordering codes GDH (bronze guide bushing)			Ordering codes GDM (ball guide bushing)	
Bore	Type	Code	Type	Code
12	UNIT MW DH 012	W0700122...	UNIT MW DM 012	W0700123...
16	UNIT MW DH 016	W0700162...	UNIT MW DM 016	W0700163...
20	UNIT MW DH 020	W0700202...	UNIT MW DM 020	W0700203...
25	UNIT MW DH 025	W0700252...	UNIT MW DM 025	W0700253...

### DIMENSIONS OF TYPE GDS

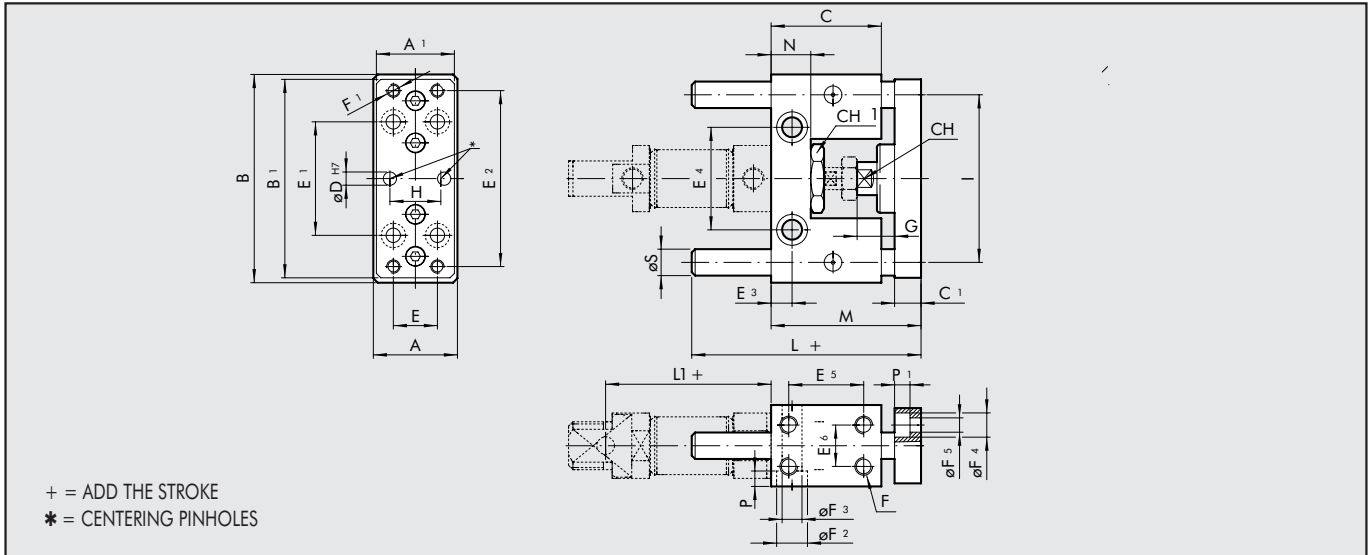

Ø	A	A <sub>1</sub>	B	B <sub>1</sub>	C	C <sub>1</sub>	Ch	Ch <sub>1</sub>	D	E	E <sub>1</sub>	E <sub>2</sub>	E <sub>3</sub>	E <sub>4</sub>	E <sub>5</sub>	E <sub>6</sub>	F	F <sub>1</sub>	F <sub>2</sub>	F <sub>3</sub>	F <sub>4</sub>	F <sub>5</sub>	G	H	I	L	L <sub>1</sub>	M	N	P	S	P <sub>1</sub>
12	30	27	65	63	38	10	8	19	4	15	32	54	6,5	24	25	22	M4	M4	8,5	5,1	7,5	4,5	15	15	46	70	53	54	13	5,5	10	4,5
16	30	27	65	63	38	10	8	19	4	15	32	54	6,5	24	25	22	M4	M4	8,5	5,1	7,5	4,5	15	15	46	70	60	54	13	5,5	10	4,5

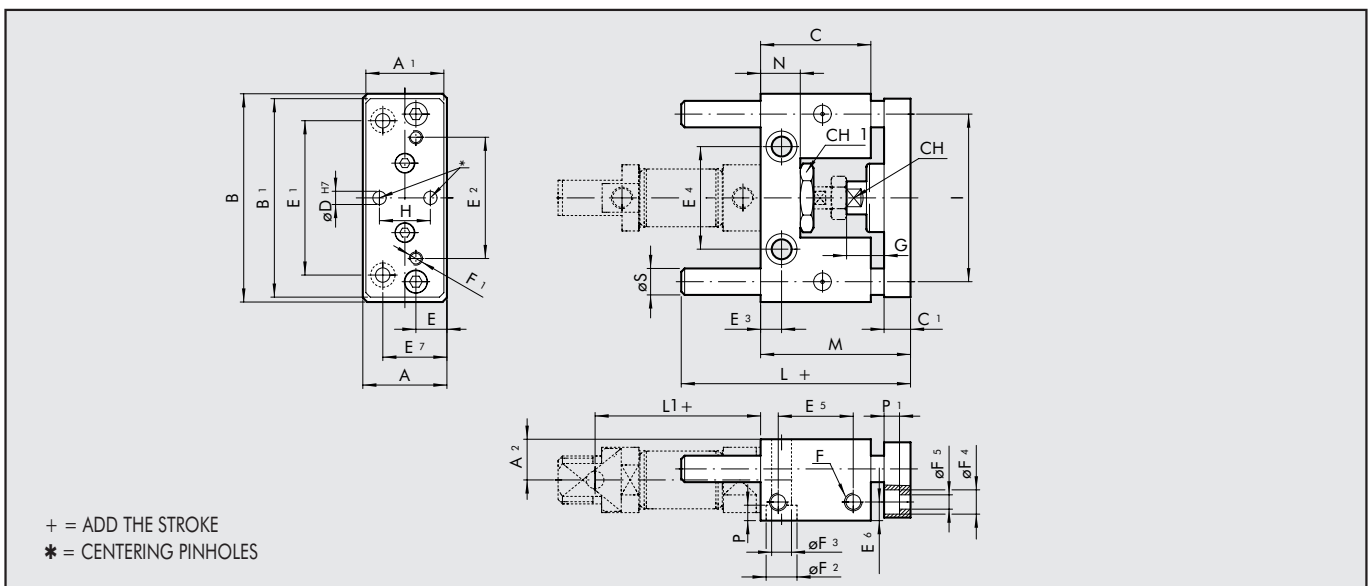

Ø	A	A <sub>1</sub>	A <sub>2</sub>	B	B <sub>1</sub>	C	C <sub>1</sub>	Ch	Ch <sub>1</sub>	D	E	E <sub>1</sub>	E <sub>2</sub>	E <sub>3</sub>	E <sub>4</sub>	E <sub>5</sub>	E <sub>6</sub>	E <sub>7</sub>	F	F <sub>1</sub>	F <sub>2</sub>	F <sub>3</sub>	F <sub>4</sub>	F <sub>5</sub>	G	H	I	L	L <sub>1</sub>	M	N	P	S	P <sub>1</sub>
20	40	38	24	100	90	48	12	13	27	6	15	70	55	8,5	46,5	32	10	30	M8	M6	14	9	11	6,5	22	20	76	77	71	65	17	9	12	6,5
25	40	38	24	100	90	48	12	13	27	6	15	70	55	8,5	46,5	32	10	30	M8	M6	14	9	11	6,5	22	20	76	77	76	71	17	9	12	6,5

Cylinder stroke	from mm.	to mm.	Guide stroke
-----------------	----------	--------	--------------

	0	50	50
	51	100	100
	101	150	150
	151	200	200
	201	250	250

**Note:**

Thanks to the dimensional features, it is possible to use the range of strokes - cylinders, as shown in the table here, without the guide piston rods projecting beyond the cylinder fixing value (L1 +).

**Ordering codes GDS (bronze guide bushing)**

Bore	Type	Code
12	UNIT MW DS 012	W0700121...
16	UNIT MW DS 016	W0700161...
20	UNIT MW DS 020	W0700201...
25	UNIT MW DS 025	W0700251...