

Mini-lubricator with high lubrication stability.

- Quantity of lubricant proportioned to air flow
- Activates at low flow rates
- Micrometric regulation of lubricant flow
- All-round oil level viewing



| TECHNICAL DATA | LUB BIT 1/8" | LUB BIT 1/4" |
|--|---|--------------|
| | Threaded port | 1/8" |
| Type of lubrication | Oil mist | |
| Bowl capacity | 26.5 cm ³ | |
| Lubricator version | Manual filling with the bowl disassembled | |
| Max. inlet pressure | MPa | |
| | bar | |
| | psi | |
| Flow rate at 6.3 bar (0.63 MPa-91 psi) ΔP 0.5 bar (0.05 MPa – 7 psi) | 400 NI/min = 14 scfm | |
| Flow rate at 6.3 bar (0.63 MPa-91 psi) ΔP 1 bar (0.1 MPa – 14 psi) | 710 NI/min = 25 scfm | |
| Fluid | Filtered compressed air | |
| Max temperature at 1 Mpa; 10 bar; 145 psi | °C | |
| | °F | |
| Weight | 40 gr | |
| Wall fixing screws | M 4 | |
| Mounting position | Vertical | |

COMPONENTS

- ① Technopolymer body with OT58 threaded elements
- ② Clear technopolymer bowl
- ③ Rilsan oil suction pipe
- ④ Filter
- ⑤ Technopolymer plug
- ⑥ Oil flow adjustment regulation needle made of OT58 brass
- ⑦ Clear technopolymer cover
- ⑧ NBR Venturi diaphragm
- ⑨ NBR gaskets

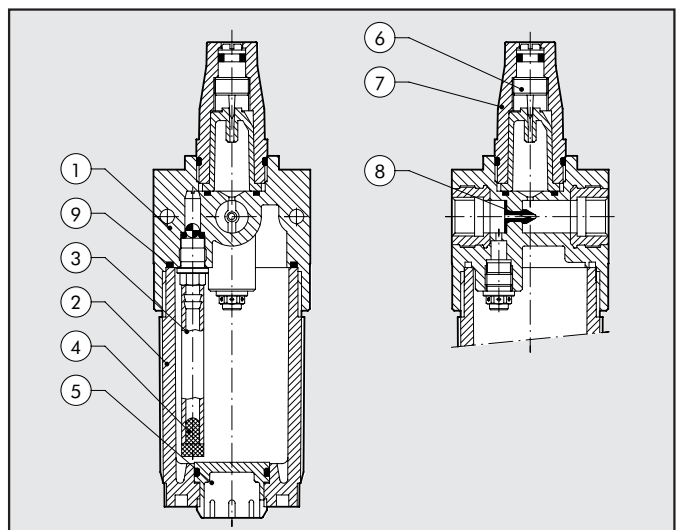

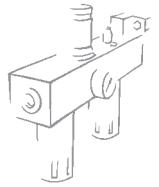

GENERAL RULES - USE AND MAINTENANCE

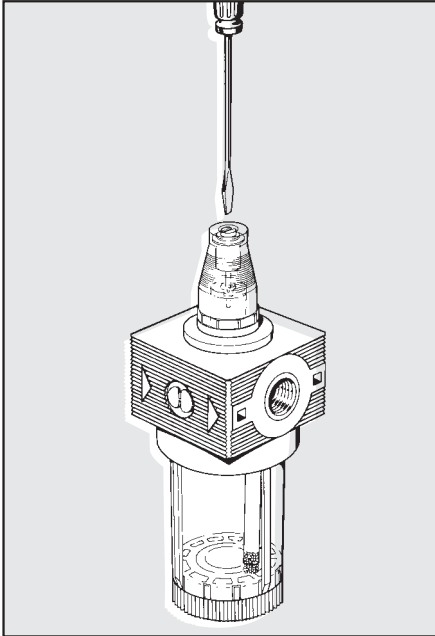

REGULATING LUBRICATION

- Use a no. 3 compass spanner to unscrew the bowl.
- Fit the lubricator as close as possible to the point of use
- Fill the bowl with oil before pressurizing the system
- Do not use cleaning oil, brake fluid or solvents in general
- For correct lubrication, set the drip rate to approximately 1 drop every 300-600 NI via the adjusting screw.
- Recommended lubricants:
ISO and UNI FD22
E.g. Energol HLP 22(BP) – Spinesso 22 (Esso) - Mobil DTE 22 (Mobil) – Tellus Oil 22 (Shell).

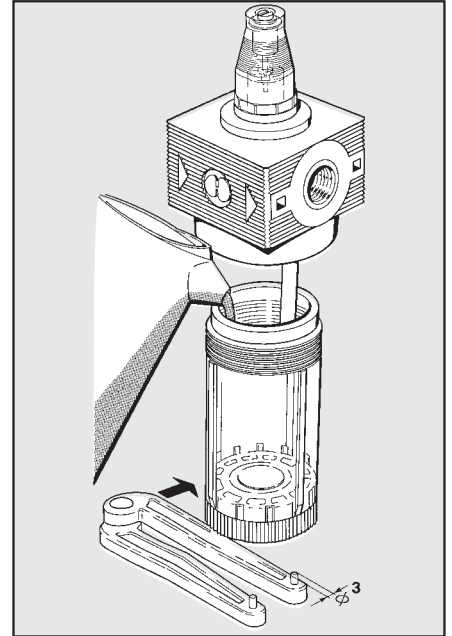

FILLING THE BOWL WITH OIL

FLOW CHARTS

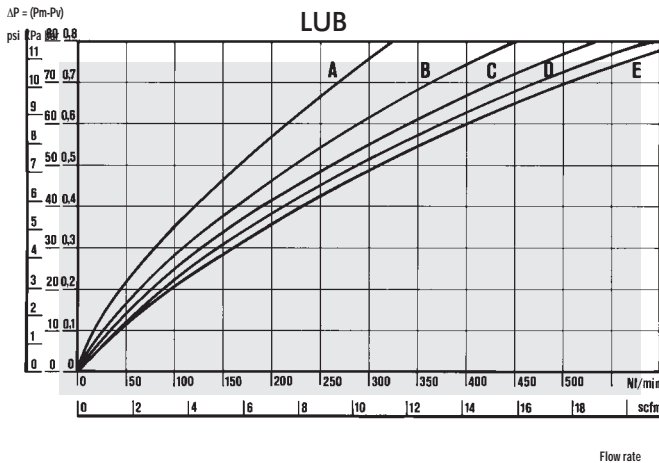

Flow rate

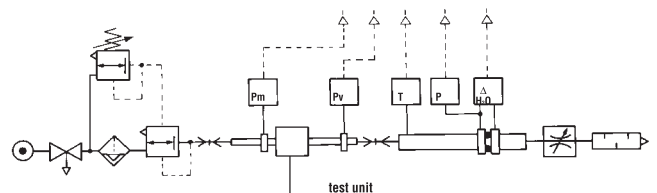

• Flow tests carried out at the Department of Mechanics, Turin Polytechnic, using the computerized test bench following CETOP RP50R recommendations (ISO DIS 6358-2-approved) with ISO 5167 diaphragm gauge.

A = 2 bar - 0,2 MPa - 29 psi
B = 4 bar - 0,4 MPa - 58 psi
C = 6 bar - 0,6 MPa - 87 psi

D = 8 bar - 0,8 MPa - 116 psi
E = 10 bar - 1 MPa - 145 psi

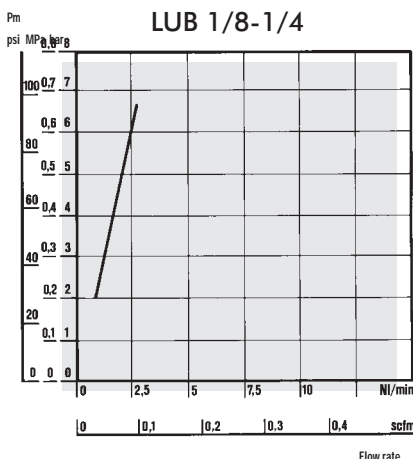

MINIMUM OPERATION FLOW CHARTS

Minimum flow tests were performed in compliance with ISO/DP 6301/2.

