

## IN-LINE FLOW REGULATOR

The in-line flow regulator regulates the speed of the piston rod in the pneumatic cylinders.

Two versions are available:

- type U (unidirectional) regulates the flow only in one of the two directions of air flow.
- type B (bidirectional) regulates the flow in both directions of air flow.

Regulation: manual or with a screwdriver.

Max. temperature 70°C (158°F)

Max. pressure: 10 bar (1MPa-145 psi)



## COMPONENTS

- ① Aluminium block
- ② Brass knob locking ring nut
- ③ Brass wall locking ring nut
- ④ Brass nipple
- ⑤ Brass adjusting knob
- ⑥ Technopolymer gasket insert
- ⑦ NBR gasket
- ⑧ Brass regulation needle
- ⑨ Part of needle
- ⑩ Flow window

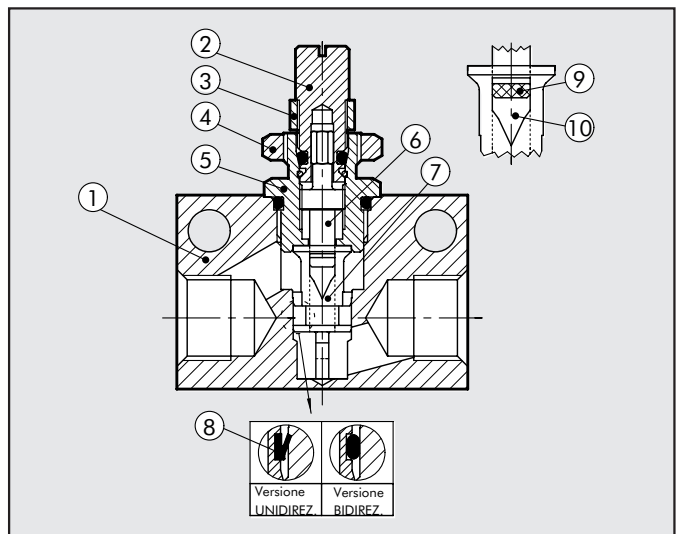

OVERALL DIMENSIONS	F	M5	1/8	1/4	3/8	1/2
P	4.2	7	8	10	11	
E	15	25	35	35	44	
H	M10x0.75	M12x1	M12x1	M15x1	M15x1	
Nmax	3.3	5.5	5	7.5	7.5	
A	21	31	45	50	59	
B	37	48	53.5	59	67	
C	14	16	20	25	30	
G	18	25	33	34	43.5	
I	11.6	15	22	22	24	
D	16	22	30	30	40	
M	12.5	18.2	24.5	25.5	35	
CH	12	16	16	20	20	
L	4.2	4.2	6.5	6.5	6.5	

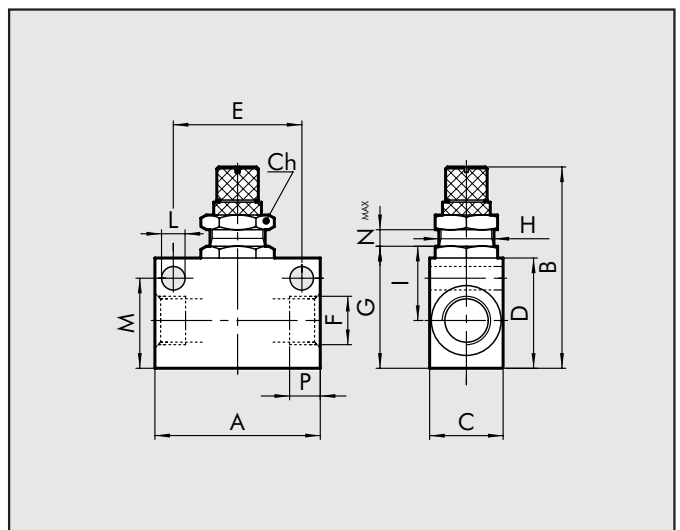



## FLOW CHARTS

### RFL M5

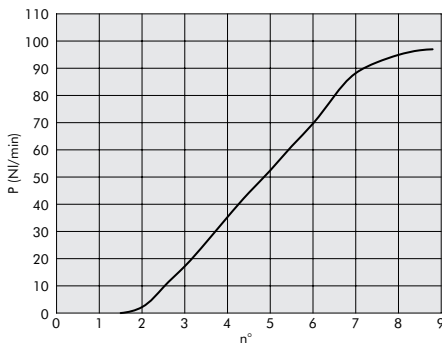

### RFL G 1/8"

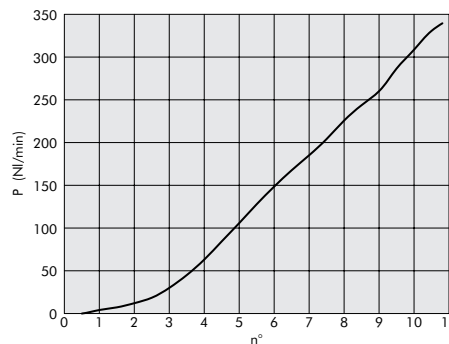

### RFL G 1/4"

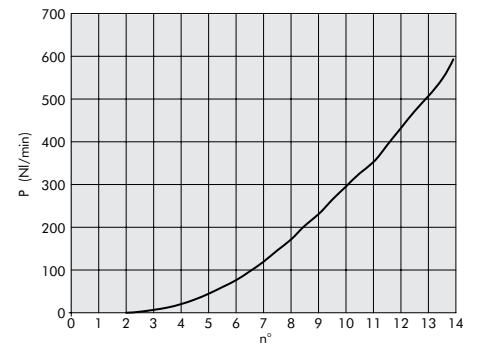

### RFL G 3/8"

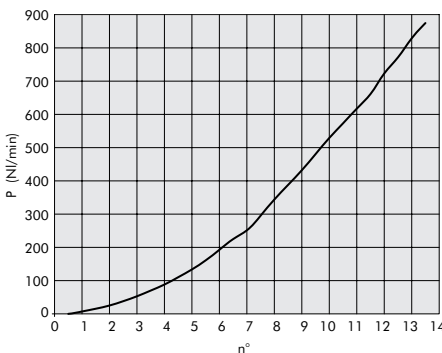

### RFL G 1/2"

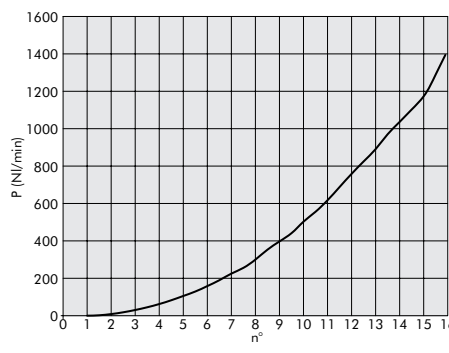

## ORDERING CODES

### RFL U (UNIDIRECTIONAL)

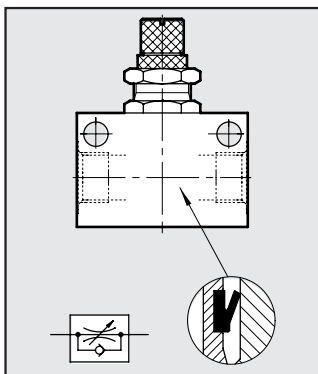

Code	Ref.
9041001	RFL U M5
9041002	RFL U 1/8
9041003	RFL U 1/4
9041004	RFL U 3/8
9041005	RFL U 1/2

### RFL B (BIDIRECTIONAL)

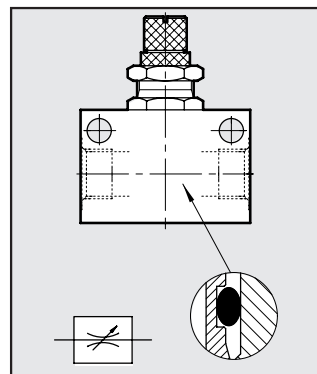

Code	Ref.
9041201	RFL B M5
9041202	RFL B 1/8
9041203	RFL B 1/4
9041204	RFL B 3/8
9041205	RFL B 1/2

## REDUCER WITH GAUGE FOR VALVES, SERIES "RMV"

The RMV-series miniature pressure regulator with pressure gauge for valves is specifically conceived for mounting on the outlets of valves with a 1/8" port. With limited cross dimension, it can be fitted to a series of small valves. The body is 16.5 mm wide and fits exactly on the valves of the Mach 16 series for multiple electrical connection.

Using the RMV, it is possible to differentiate the pressure of each single output of the valves. For example, if you mount it on port 2 and not on port 4, the pressure can be reduced on port 2 only. If you mount one for each port, the pressure on port 2 will differ from that on port 4, which in turn is less than the feed pressure (outlet 1).

There are three 1/8" threaded RMV ports that are pneumatically connected in parallel. A small pressure gauge is mounted in one port; another port is plugged by an A7-type fitting and a third can take a fitting. The user, however, can decide whether the layout of components is to be modified or not. He might, for example, decide to mount three fittings to create a three-port reduced-pressure distributor.

For information please see pag. 2.1/106.

