

The role of the depurator is to separate the liquid and solid particles contained in the compressed air with a high degree of efficiency. This separation is carried out using a special filtering element called a "coalescence cartridge".



| TECHNICAL DATA | DEP 100 | DEP 100 | DEP 200 | DEP 200 | DEP 200 | DEP 300 | DEP 300 | DEP 300 | |
|--|-------------------|---|---------|---------|-------------------------|---------|---------|---------|--|
| Threaded port | G 1/4 | G 3/8 | G 1/4 | G 3/8 | G 1/2 | G 1/2 | G 3/4 | G 1" | |
| Degree of filtering | 99.97% at 0.01 µm | | | | | | | | |
| Max. inlet pressure | MPa | 1.5 | | | | 1.3 | | | |
| | Bar | 15 | | | | 13 | | | |
| | psi | 217 | | | | 188 | | | |
| Flow rate at 6.3 bar (0.63 MPa-91 psi) | NI/min | 750 | | 1200 | | 2800 | | | |
| ΔP 0.5 bar (0.05 MPa – 7 psi) | scfm | 27 | | 43 | | 100 | | | |
| Flow rate at 6.3 bar (0.63 MPa-91 psi) | NI/min | 1100 | | 1700 | | 4200 | | | |
| ΔP 1 bar (0.1 MPa – 14 psi) | scfm | 39 | | 61 | | 150 | | | |
| Fluid | 5µm filtered air | | | | | | | | |
| Max temperature | °C | 50 | | | | | | | |
| at 1 MPa; 10 bar; 145 psi | °F | 122 | | | | | | | |
| Weight | Kg | 0.4 | | 0.9 | | 1.4 | | | |
| Wall fixing screws | | M4 x 50 | | M5 x 60 | | M5 x 70 | | | |
| Mounting position | | Vertical | | | | | | | |
| Bowl capacity | cm ³ | 22 | | 45 | | 75 | | | |
| Drain | | Manual/Semi-auto (RMSA) | | | Manual/Semi-auto (RMSA) | | | | |
| | | Automatic (SAC) | | | Automatic (RA) | | | | |
| Notes on use | | It is advisable to mount a 5mm pre-filter in order to separate the solid particles first. | | | | | | | |

HOW THE COALESCENCE CARTRIDGE WORKS

Air from the mains – full of impurities – flows into the coalescence cartridge and then passes through the crossed micro-fibres that make up the cartridge. During this movement the liquid particles come into contact with the crossed micro-fibres and adhere to them. Due to the air pressure and gravity they join up with other micro-drops at each cross-over point and gradually increase in volume, leading to the physical phenomenon called coalescence. When they stop moving, the drops deposit on the outside of the cartridge, from which they detach and drop to the bottom. Since the volume of liquid leaving the cartridge is exactly the same as the drops arriving, the coalescence cartridge ought to work indefinitely. Solid particles are caught with the same efficiency but, unlike drops, they are not drained out and clog the cartridge. To get round this problem, it is necessary to mount a 5mm pre-filter before the fine oil filter to separate the solid particles first.

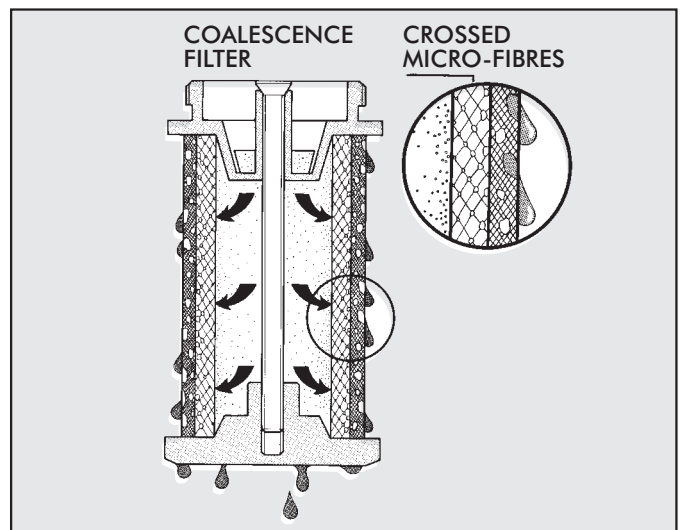

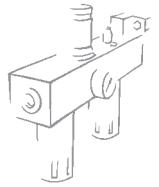

FLOW CHARTS

DEP 100 1/4 - 3/8

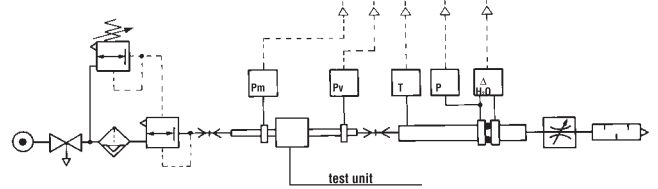
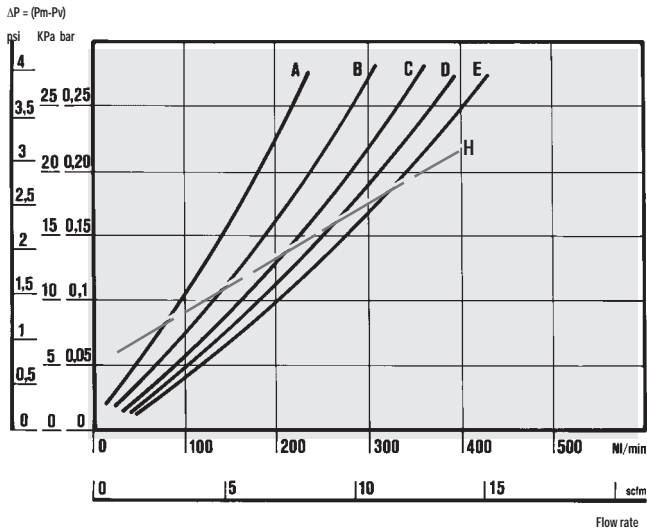

• Flow tests carried out at the Department of Mechanics, Turin Polytechnic, using the computerized test bench following CETOP RP50R recommendations (ISO DIS 6358-2-approved) with ISO 5167 diaphragm gauge.

(A) = 2 bar - 0,2 MPa - 29 psi
 (B) = 4 bar - 0,4 MPa - 58 psi
 (C) = 6 bar - 0,6 MPa - 87 psi

(D) = 8 bar - 0,8 MPa - 116 psi
 (E) = 10 bar - 1 MPa - 145 psi
 (H) = maximum flow rate recommended for optimal operation

DEP 200 1/4 - 3/8 - 1/2

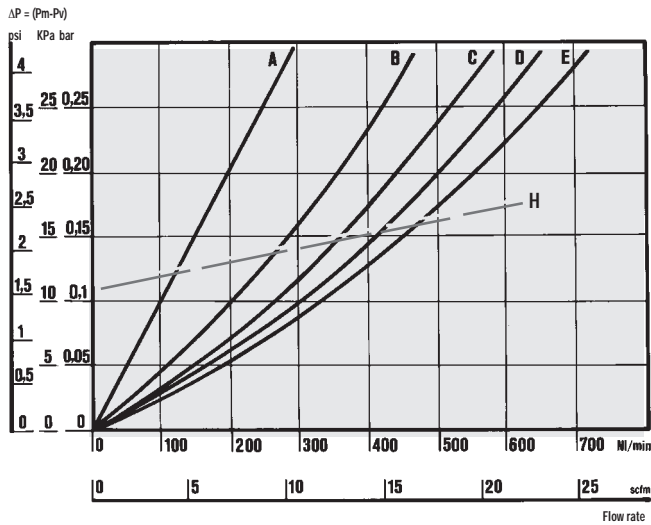

DEP 300 1/2 - 3/4 - 1

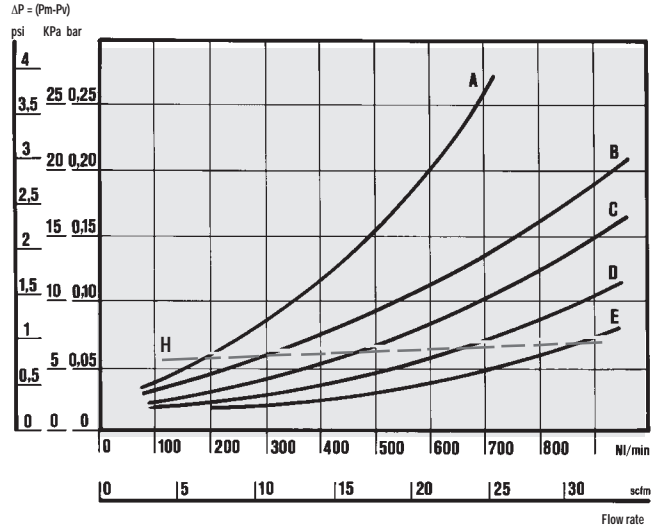

DIMENSIONS

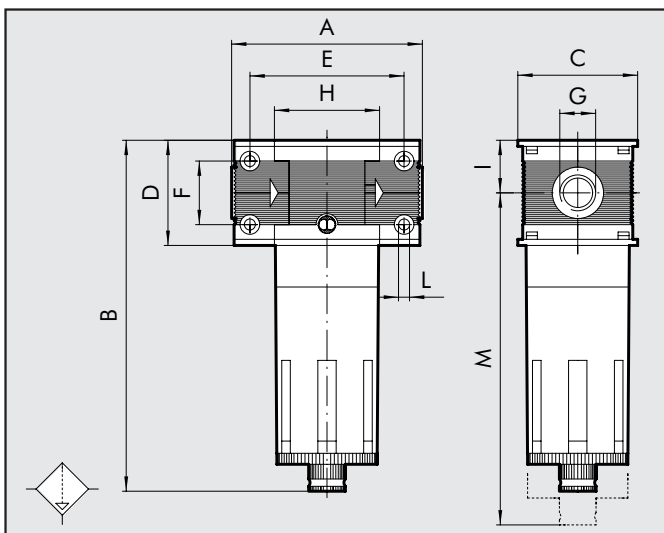

| | DEP 100 | DEP 100 | DEP 200 | DEP 200 | DEP 200 | DEP 300 | DEP 300 | DEP 300 |
|--------|---------|---------|---------|---------|---------|---------|---------|---------|
| Th. p. | G 1/4 | G 3/8 | G 1/4 | G 3/8 | G 1/2 | G 1/2 | G 3/4 | G 1" |
| A | 78 | | | 93.5 | | 110 | | 112 |
| B | 144 | | | 175 | | | 195 | |
| C | 50 | | | 63 | | | 72 | |
| D | 43 | | | 55 | | | 65 | |
| E | 63 | | | 78.5 | | | 92 | |
| F | 26 | | | 36 | | | 42 | |
| G | G 1/4 | G 3/8 | G 1/4 | G 3/8 | G 1/2 | G 1/2 | G 3/4 | G 1" |
| H | 43 | | | 55.5 | | | 65 | |
| I | 21.5 | | | 27.5 | | | 32.5 | |
| L | M4 hole | | | M5 hole | | | M5 hole | |
| M | 137 | | | 196 | | | 215 | |

Skillair® 400 DEPURATOR

- Coalescence cartridge with a very high degree of filtration
- Metal bowl with bayonet coupling, safety lock and 360° condensate display
- Manual/semi-auto condensate drain
- Optional activated carbon cartridge with 0.003 ppm oil residue (food industry, pharmaceuticals, cosmetics).



| TECHNICAL DATA | DEP 400 | | | |
|--|---|---------|---------|------|
| | G 1" | G 1"1/4 | G 1"1/2 | G 2" |
| Threaded port | | | | |
| Degree of filtration | 99.99% at 0.01 µm | | | |
| Max. inlet pressure | 1.3 MPa 13 Bar 188 psi | | | |
| Flow rate at 6.3 bar (0.63 MPa-91 psi) | 8.000 NI/min | | | |
| ΔP 0.5 bar (0.05 MPa – 7 psi) | 284 scfm | | | |
| Fluid | 5 µm filtered air | | | |
| Max temperature | 50 °C 122 °F | | | |
| Weight | 4.2 Kg | | 5 Kg | |
| Wall fixing screws | M6x110 | | | |
| Mounting position | Vertical | | | |
| Drain | Manual/semi-auto (RMSA) - Automatic (RA) | | | |
| Bowl capacity | 270 cm³ | | | |
| Notes on use | It is advisable to mount a 5mm pre-filter in order to separate the solid particles first. Series 400 end plates come with a patented system with a rotary sliding end joint to allow the unit to be adapted to the pipe cutting distance (see page 3.1/03). | | | |

| DIMENSIONS | LUB 400 | | | |
|---------------|---------|---------|---------|------|
| | G 1" | G 1"1/4 | G 1"1/2 | G 2" |
| Threaded port | | | | |
| A | 225÷255 | | | |
| B | 320 | | | |
| C | 116 | | | |
| D | 105 | | | |
| E | 141.4 | | | |
| F | 80 | | | |
| G | G 1" | G 1"1/4 | G 1"1/2 | G 2" |
| H | 105.4 | | | |
| I | 52.5 | | | |
| L | M6 hole | | | |
| M | 378 | | | |

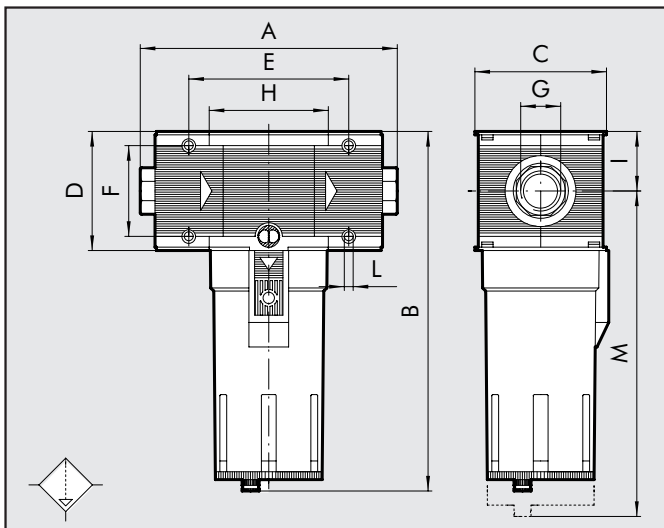

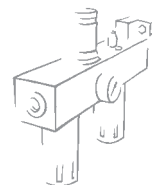

FLOW CHARTS

DEP 400 1''

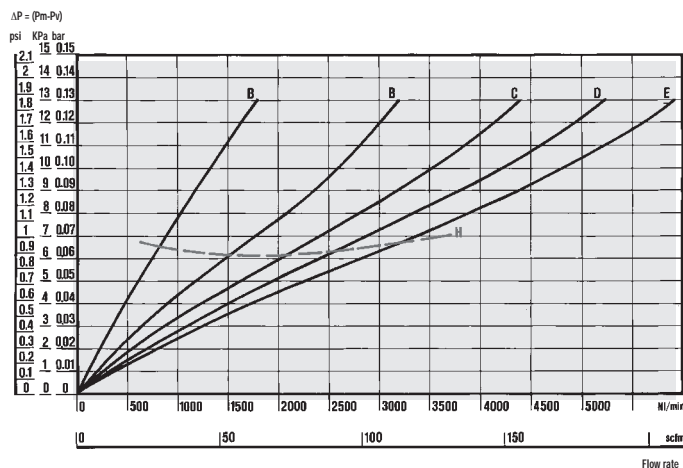

DEP 400 2''

(A) = 2 bar - 0,2 MPa - 29 psi (D) = 8 bar - 0,8 MPa - 116 psi
 (B) = 4 bar - 0,4 MPa - 58 psi (E) = 10 bar - 1 MPa - 145 psi
 (C) = 6 bar - 0,6 MPa - 87 psi (H) = Maximum flow rate recommended for optimal operation.

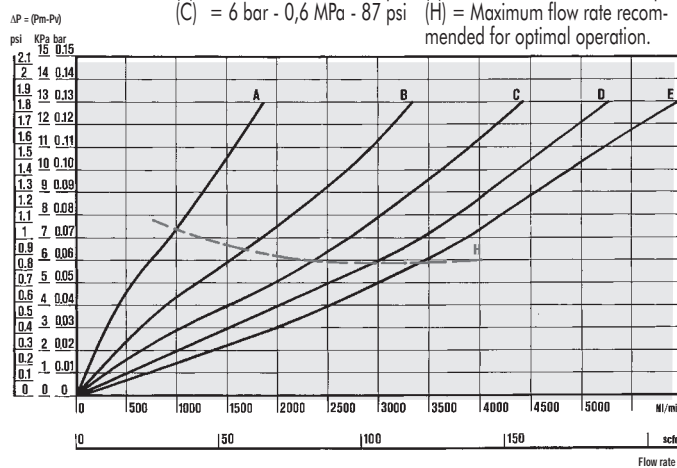

KEY TO CODES

| DEP ELEMENT | 100 SIZE | 1/4 3/8 1/2 3/4 1 1 1/4 1 1/2 2 THREADED PORT | RMSA TYPE OF DRAIN |
|-------------|----------|---|--------------------|
| DEP | 100 | 1/4 | RMSA |
| | 200 | 1/4 | |
| | 300 | 1/2 | RMSA |
| | 400 | 3/4 | RA |
| | | 1 | |
| | | 1 1/4 | |
| | | 1 1/2 | |
| | | 2 | |

RMSA: Manual/semi-auto drain
 RA: Automatic drain. Float-type operation irrespective of the pressure and flow rate.

ORDERING CODES

| Code | Description | Code | Description | Code | Description |
|-------------------------------|-------------------------------|----------|-------------------------------|----------|-------------------------------|
| SKILLAIR 100 DEPURATOR | | | | | |
| 3288001A | D 100 RMSA WITHOUT END PLATES | 4488001A | D 300 RMSA WITHOUT END PLATES | 6188001A | D 400 RMSA WITHOUT END PLATES |
| 3288002A | D 100 SAC WITHOUT END PLATES | 4488002A | D 300 RA WITHOUT END PLATES | 6188002A | D 400 RA WITHOUT END PLATES |
| 3288001 | D 100 1/4 RMSA | 4488001 | D 300 1/2 RMSA | 6188001 | D 400 1 RMSA |
| 3288002 | D 100 1/4 SAC | 4488002 | D 300 1/2 RA | 6188002 | D 400 1 RA |
| 3388001 | D 100 3/8 RMSA | 4588001 | D 300 3/4 RMSA | 6288001 | D 400 1 1/4 RMSA |
| 3388002 | D 100 3/8 SAC | 4588002 | D 300 3/4 RA | 6288002 | D 400 1 1/4 RA |
| SKILLAIR 200 DEPURATOR | | | | | |
| 3488001A | D 200 RMSA WITHOUT END PLATES | 4688001 | D 300 1 RMSA | 6388001 | D 400 1 1/2 RMSA |
| 3488002A | D 200 SAC WITHOUT END PLATES | 4688002 | D 300 1 RA | 6388002 | D 400 1 1/2 RA |
| 3488001 | D 200 1/4 RMSA | | | 6488001 | D 400 2 RMSA |
| 3488002 | D 200 1/4 SAC | | | 6488002 | D 400 2 RA |
| 3588001 | D 200 3/8 RMSA | | | | |
| 3588002 | D 200 3/8 SAC | | | | |
| 3688001 | D 200 1/2 RMSA | | | | |
| 3688002 | D 200 1/2 SAC | | | | |