

FLOW MICROREGULATORS NEW SERIES

The job of flow microregulators is to regulate speed in the pneumatic cylinders.

The configuration of both type C (to be mounted on the cylinder inlet) and type V (to be mounted on the valve port) is such as to ensure full flow on feed and regulated flow on discharge. Type B (bidirectional) can be used to regulate the flow both on feed and discharge.

Flow microregulators are divided into 4 series:

- **MRF COMPACT O:** can be adjusted using a screwdriver; the regulation pin is lubricated with a particular antivibration grease; it has reduced dimensions and fine adjustment in the first turns; adjustment can be prevented by assembling a disposable cap (supplied separately) that can be removed using a tool.
- **MRF COMPACT N:** can be adjusted using the knob and/or screwdriver; adjustment can be prevented by tightening the ring nut; it has the same regulation curve as those in series O.
- **MRF HIGH-FLOW:** can be adjusted using the knob and/or screwdriver; adjustment can be prevented by tightening the ring nut; it is ideal for use in installations requiring high flow rates both on regulation and discharge. Available in 1/8" and 1/4" and with a technopolymer ring.
- **MRF PUSH-LOCK:** it is the only one in the MRF series with a PUSH-LOCK knob, that can be replaced by an anti-tampering knob (supplied separately). Available in 1/8" and 1/4" and with a technopolymer ring.

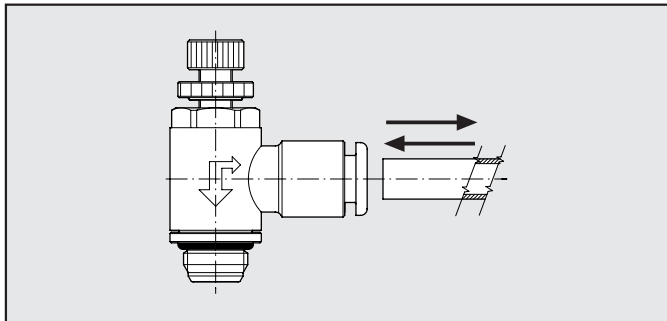

All the MRF with a pipe engage-release system of the latest generation that facilitates detachment of the pipe even under difficult operating conditions.

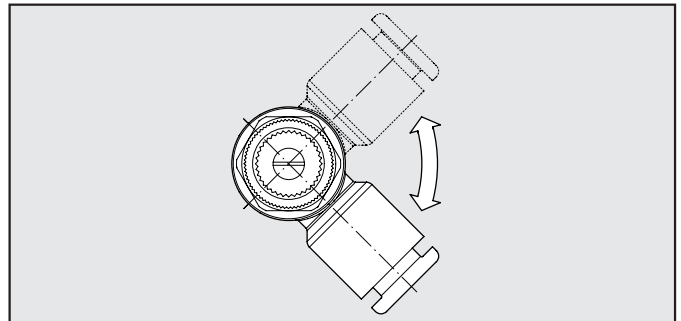

The rings can be rotated even with the MRF installed, which means that they can be mounted with the pipe facing towards any direction.

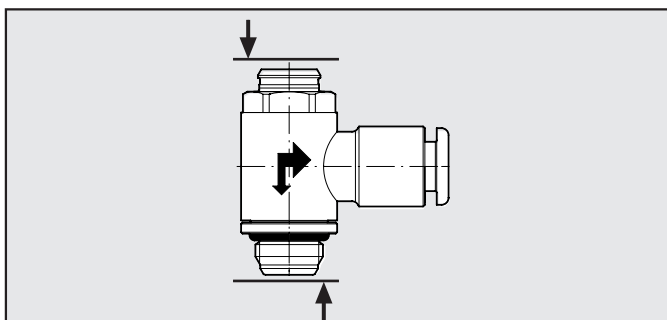

Special focus has been placed on miniaturisation of the components (mainly for COMPACT MRF series O), which saves considerable space.



The regulation curve in the MRF series COMPACT N, COMPACT O and PUSH-LOCK takes place in two sections: in the first half of the flash pin stroke for very fine regulation and relatively low flow rates; in the second half, the flash pin quickly opens the passage so as to reach the maximum flow rate quickly.

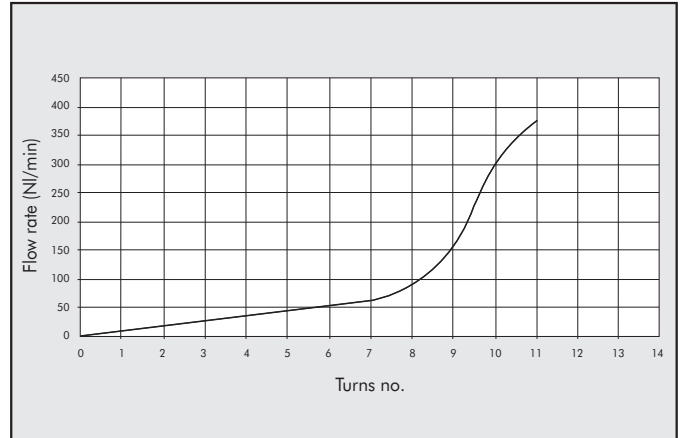

The regulation curve in the MRF series HIGH-FLOW is divided into 3 sections: regulation is particularly accurate along the entire flash pin stroke and the maximum flow rate is reached at a good steady rate; in this way, the user can choose the solution which best fits the specific application.

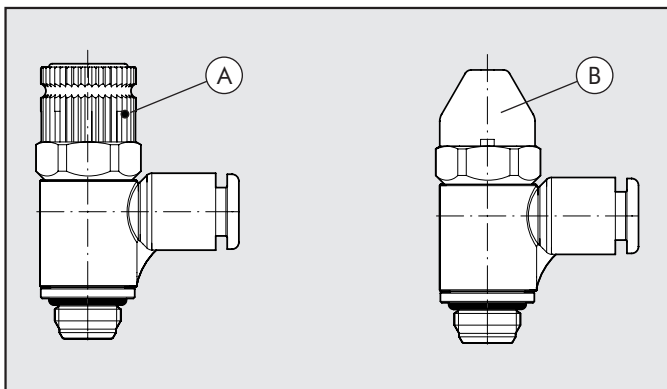
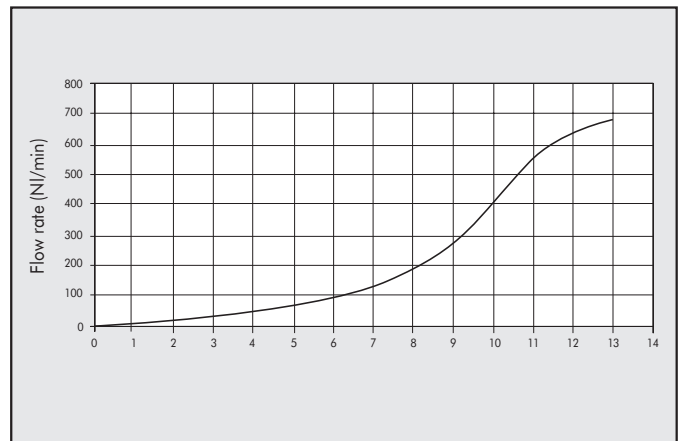

A major innovative aspect of the new MRF is the possibility of using the PUSH-LOCK series that can be mounted with either a push-lock (A) or an anti-tampering knob (B). The push-lock knob prevents decalibration of the MRF due to vibration or incorrect torque. With the anti-tampering knob there is no way to change the position unless you remove the knob using a special tool.

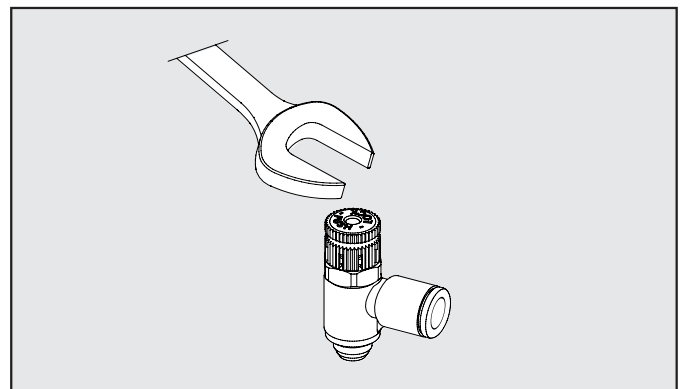

All the new MRF can be fixed from the top using a universal wrench, a pipe wrench or an automatic screwdriver.

THREAD	MAXIMUM TORQUE (Nm)*
M5	max 1,8
G 1/8"	max 6
G 1/4"	max 8
G 3/8"	max 10
G 1/2"	max 15

* measured on a metal female thread